

---

DO NOT OPEN THIS TEST BOOKLET UNTIL YOU ARE ASKED TO DO SO

---

T.B.C. : MKA-S-MEN

Test Booklet Series

Serial No.

TEST BOOKLET  
MECHANICAL ENGINEERING

**B**

Time Allowed : Three Hours

Maximum Marks : 300

---

INSTRUCTIONS

1. IMMEDIATELY AFTER THE COMMENCEMENT OF THE EXAMINATION, YOU SHOULD CHECK THAT THIS TEST BOOKLET **DOES NOT** HAVE ANY UNPRINTED OR TORN OR MISSING PAGES OR ITEMS, ETC. IF SO, GET IT REPLACED BY A COMPLETE TEST BOOKLET.
2. Please note that it is the candidate's responsibility to encode and fill in the Roll Number and Test Booklet Series A, B, C or D carefully and without any omission or discrepancy at the appropriate places in the OMR Answer Sheet. Any omission/discrepancy will render the Answer Sheet liable for rejection.
3. You have to enter your Roll Number on the Test Booklet in the Box provided alongside. **DO NOT** write *anything else* on the Test Booklet. 
4. This Test Booklet contains 150 items (questions). Each item comprises four responses (answers). You will select the response which you want to mark on the Answer Sheet. In case you feel that there is more than one correct response, mark the response which you consider the best. In any case, choose **ONLY ONE** response for each item.
5. You have to mark your responses **ONLY** on the separate Answer Sheet provided. See directions in the Answer Sheet.
6. All items carry equal marks.
7. Before you proceed to mark in the Answer Sheet the response to various items in the Test Booklet, you have to fill in some particulars in the Answer Sheet as per instructions sent to you with your Admission Certificate.
8. After you have completed filling in all your responses on the Answer Sheet and the examination has concluded, you should hand over to the Invigilator *only the Answer Sheet*. You are permitted to take away with you the Test Booklet.
9. Sheets for rough work are appended in the Test Booklet at the end.
10. **Penalty for wrong answers :**  
THERE WILL BE PENALTY FOR WRONG ANSWERS MARKED BY A CANDIDATE.
  - (i) There are four alternatives for the answer to every question. For each question for which a wrong answer has been given by the candidate, **one-third (0.33)** of the marks assigned to that question will be deducted as penalty.
  - (ii) If a candidate gives more than one answer, it will be treated as **wrong answer** even if one of the given answers happens to be correct and there will be same penalty as above to that question.
  - (iii) If a question is left blank, i.e., no answer is given by the candidate, there will be **no penalty** for that question.

---

DO NOT OPEN THIS TEST BOOKLET UNTIL YOU ARE ASKED TO DO SO

---

1. A beam of rectangular section (12 cm wide  $\times$  20 cm-deep) is simply supported over a span of 12 m. It is acted upon by a concentrated load of 80 kN at the mid-span. The maximum bending stress induced is

- (a) 400 MPa
- (b) 300 MPa
- (c) 200 MPa ✓
- (d) 100 MPa

2. A uniform bar, simply supported at the ends, carries a concentrated load  $P$  at mid-span. If the same load be, alternatively, uniformly distributed over the full length of the bar, the maximum deflection of the bar will decrease by

- (a) 25.5% ✓
- (b) 31.5%
- (c) 37.5%
- (d) 50.0%

3. A thin cylindrical pressure vessel and a thin spherical pressure vessel have the same mean radius, same wall thickness and are subjected to same internal pressure. The hoop stresses set up in these vessels (cylinder in relation to sphere) will be in the ratio

- (a) 1 : 2
- (b) 1 : 1
- (c) 2 : 1
- (d) 4 : 1 ✓

4. A boy walks up a stalled escalator in 90 seconds. When the same escalator moves, he is carried up in 60 seconds. How much time would it take him to walk up the moving escalator?

- (a) 48 seconds
- (b) 36 seconds ✓
- (c) 30 seconds
- (d) 24 seconds

5. A 10 mm diameter bar of mild steel of elastic modulus  $200 \times 10^9$  Pa is subjected to a tensile load of 50000 N, taking it just beyond its yield point. The elastic recovery of strain that would occur upon removal of tensile load will be

- (a)  $1.38 \times 10^{-3}$  ✓
- (b)  $2.68 \times 10^{-3}$
- (c)  $3.18 \times 10^{-3}$
- (d)  $4.62 \times 10^{-3}$

6. On completion of heat treatment, the austenite structure would be retained if

- (a) the rate of cooling is greater than the critical cooling rate
- (b) the rate of cooling is less than the critical cooling rate ✓
- (c) the initiating temperature of martensite formation is above the room temperature
- (d) the finishing temperature of martensite formation is below the room temperature

7. Which one of the following statements is correct?

- (a) Iron-carbon and TTT diagrams are both equilibrium diagrams.
- (b) Iron-carbon and TTT diagrams are both non-equilibrium diagrams.
- (c) Iron-carbon diagram is an equilibrium diagram but TTT diagram is a non-equilibrium diagram.
- (d) Iron-carbon diagram is a non-equilibrium diagram but TTT diagram is an equilibrium diagram.

8. The correct order of increasing resistivity among the following materials is

- (a) nickel, doped silicon, sodium silicate, pure silica
- ~~(b)~~ doped silicon, nickel, pure silica, sodium silicate
- (c) nickel, pure silica, sodium silicate, doped silicon
- (d) sodium silicate, nickel, pure silica, doped silicon

9. Consider the following statements :

On heating an elastomer under tensile load, its shrinkage

1. maximizes the enthalpy
2. maximizes the entropy
3. minimizes the free energy
4. avoids breaking

Which of the above statements are correct?

- (a) 1 and 2
- (b) 2 and 3
- (c) 3 and 4
- (d) 1 and 4

10. Which of the following properties will be the meaningful indicator/indicators of uniform rate of elongation of a test piece of a structural material before necking happens in the test piece?

1. Ductility
2. Toughness
3. Hardness

Select the correct answer using the code given below.

- (a) 1 only
- (b) 2 only
- (c) 3 only
- (d) 1, 2 and 3 ✓

11. Which one of the following alloying elements increases the corrosion resistance of steel?

- (a) Vanadium
- (b) Chromium
- ~~(c)~~ Nickel
- (d) Copper

12. Which of the following mechanisms are examples of forced closed kinematic pairs?

- ~~1.~~ Cam and roller mechanism
2. Door-closing mechanism
- ~~3.~~ Slider-crank mechanism

Select the correct answer using the code given below.

- (a) 1 and 2 only
- (b) 1 and 3 only
- (c) 2 and 3 only
- (d) 1, 2 and 3

13. A planer mechanism has 10 links and 12 rotary joints. Using Grubler's criterion, the number of degrees of freedom of the mechanism is

- (a) 1
- (b) 3
- (c) 2
- (d) 4

14. The displacement and velocity diagrams of a cam and follower mechanism are shown :

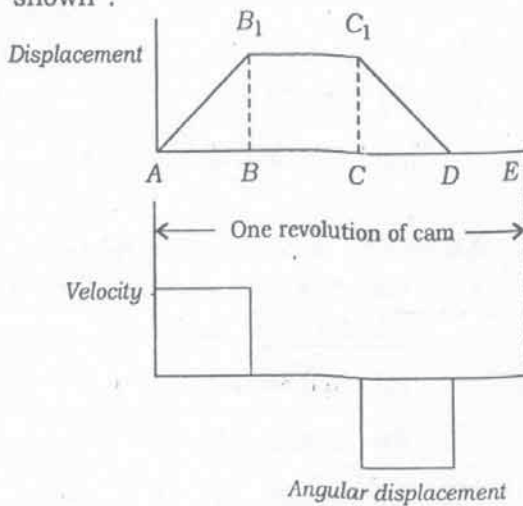

Which of the following statements is/are correct?

- 1. The acceleration of the follower at the beginning and at the end of each stroke will be zero.
- 2. The follower remains at rest in the dwell period.
- 3. During period DE, the motion of the follower is retarding.

Select the correct answer using the code given below.

- (a) 1, 2 and 3
- (b) 1 only
- (c) 2 only
- (d) 3 only

15. The number of instantaneous centres of rotation in a slider-crank quick-return mechanism is

- (a) 10
- (b) 8
- (c) 6
- (d) 4

16. A simple spring-mass vibrating system has a natural frequency of  $N$ . If the spring stiffness is halved and the mass doubled, then the natural frequency will be

- (a)  $0.5N$
- (b)  $N$
- (c)  $2N$
- (d)  $4N$

17. A car of mass  $1450 \text{ kg}$  is constructed on a chassis supported by four springs. Each spring has a force constant of  $40000 \text{ N m}$ . The combined mass of the two people occupying the car is  $150 \text{ kg}$ . What is the period of execution of two complete vibrations?

- (a)  $0.63 \text{ s}$
- (b)  $1.59 \text{ s}$
- (c)  $4.96 \text{ s}$
- (d)  $1.26 \text{ s}$

$$\frac{m}{k} = \frac{150}{40000} = 0.00375$$

$$T = 2\pi \sqrt{\frac{m}{k}} = 2\pi \sqrt{0.00375} = 0.63 \text{ s}$$

18. Consider the following statements :

Artefacts to prevent harmful effects resulting from vibrations of an unbalanced machine fixed on its foundation include

1. mounting the machine on springs thereby minimizing the transmission of forces
2. using vibration isolating materials to prevent or reduce the transmission of forces
3. moving the foundation so as to have only one degree of freedom towards reducing the transmission of forces

Which of the above statements are correct?

- (a) 1 and 2 only  
 (b) 1 and 3 only  
 (c) 2 and 3 only  
 (d) 1, 2 and 3

19. Two heavy rotors are mounted on a single shaft. Considering each of the rotors separately, the transverse natural frequencies are 100 cycles/s and 200 cycles/s, respectively. The lower critical speed will be

- (a) 12000 r.p.m.  
 (b) 9360 r.p.m.  
 (c) 8465 r.p.m.  
 (d) 5367 r.p.m.

Handwritten solution for Q19:

$$f_1 = 100$$

$$f_2 = 200$$

$$n_1 = \frac{f_1}{f_2} \times \frac{NR_1}{NR_2}$$

$$= \frac{100 \times 3600 \times 60}{200 \times 3600}$$

20. Consider the following statements :

In the case of gears of involute profiles, increase in the centre to centre distances between the mounting shafts

1. increases the pressure angle
2. will not affect the law of gearing
3. shortens the path of contact
4. increases the contact ratio

Which of the above statements are correct?

- (a) 1, 2 and 4  
 (b) 1, 2 and 3  
 (c) 1, 3 and 4 ✓  
 (d) 2, 3 and 4

21. A rigid bar ACO as shown is hinged at O and is held in a horizontal position by two identical vertical steel wires AB and CD. A point load of 20 kN is hung at the position shown. The tensions in wires AB and CD are

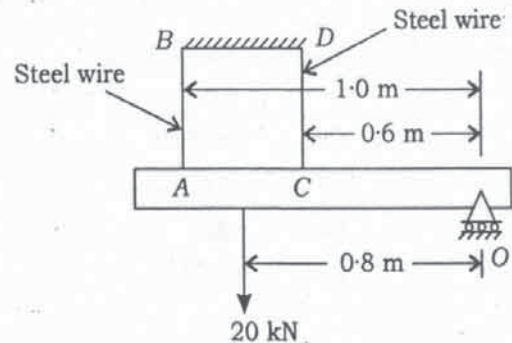

- (a) 15.2 kN and 7.1 kN  
 (b) 11.8 kN and 7.1 kN ✓  
 (c) 15.2 kN and 5.0 kN  
 (d) 11.8 kN and 5.0 kN

22. An epicyclic gear train has 3 shafts A, B and C. A is the input shaft running at 100 r.p.m. clockwise. B is the output shaft running at 250 r.p.m. clockwise. The torque on A is 50 kN m (clockwise), C is a fixed shaft. The torque needed to fix C is

- (a) 20 kN m (anti-clockwise)  
 (b) 20 kN m (clockwise)  
 (c) 30 kN m (anti-clockwise)  
 (d) 30 kN m (clockwise)

23. A fixed gear having  $200$  teeth is meshed with a smaller gear having  $50$  teeth. The two gears are connected by an arm. The number of turns made by the smaller gear for one revolution of the arm about the centre of the bigger gear is

- (a) 1  
 (b) 2  
 (c) 3  
 (d) 5

$n = 200$   
 $\frac{200}{50} = 4$   
 $\frac{4}{1} = 4$

24. Consider the following statements :

- Balancing of several masses rotating in the same plane can be effected by a single mass.
- Balancing of several masses in different planes can be done by 2 masses in 2 planes on either side of the reference plane or on the same side.
- Reciprocating masses cannot be completely balanced by rotating masses.
- Secondary unbalanced forces will be negligible compared to primary imbalance forces.

Which of the above statements are correct?

- (a) 1, 2, 3 and 4  
 (b) 1, 2 and 3 only  
 (c) 3 and 4 only  
 (d) 1, 2 and 4 only

25. A body of mass 10 kg with its CG 200 mm from the axis of rotation is to be completely balanced by another mass B of 5 kg placed in the same plane. The radius at which the CG of mass B should be is

- (a) 500 mm  
 (b) 400 mm ✓  
 (c) 300 mm  
 (d) 200 mm

26. Consider the following statements :

- In stationary constant speed engines, the spring-loaded governor mechanism is fitted on the camshaft of the engine.
- Hunting occurs when the governor is not sensitive.
- Isochronous governors have the same speed over a wide range of governor action.
- A governor is said to be unstable if the radius of rotation falls as the speed increases.

Which of the above statements are correct?

- (a) 1, 2, 3 and 4  
 (b) 1, 2 and 4 only  
 (c) 1, 3 and 4 only ✓  
 (d) 2 and 3 only

27. An aircraft cruising at 360 kmph takes a right turn on an arc of 100 m radius. The turbines and propellers have a total mass of 500 kg with radius of gyration of 25 cm. The engine rotates at 2000 r.p.m. The magnitude of the gyroscopic couple generated is

(a) 6.55 kN m

(b) 7.65 kN m

(c) 9.81 kN m ✓

(d) 13.1 kN m

28. The maximum shearing stress induced in the beam section at any layer at any position along the beam length (shown in the figure) is equal to

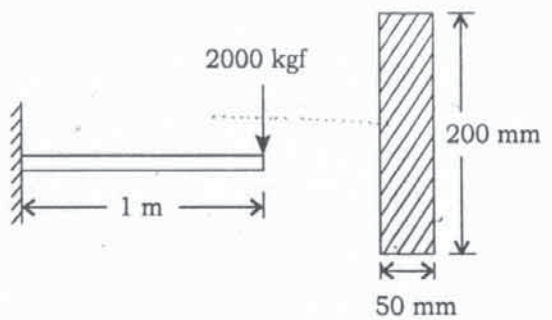

Cross-section of beam

(a) 30 kgf/cm<sup>2</sup>

(b) 40 kgf/cm<sup>2</sup> ✓

(c) 50 kgf/cm<sup>2</sup>

(d) 60 kgf/cm<sup>2</sup>

$$\frac{I \times b}{w} = \frac{1000}{1000}$$

29. Consider the following statements :

For a component made of ductile material, the failure criterion will be

1. endurance limit, if the external force is fluctuating
2. fatigue, if the external force is fluctuating
3. yield stress, if the external force is static

Which of the above statements are correct?

(a) 1 and 2 only

(b) 1 and 3 only

(c) 2 and 3 only

(d) 1, 2 and 3 ✓

30. A machine component is subjected to a flexural stress, which fluctuates between 300 MN/m<sup>2</sup> and -150 MN/m<sup>2</sup>. Taking the yield strength = 0.55 of the ultimate strength, endurance strength = 0.50 of the ultimate strength and factor of safety to be 2, the value of the minimum ultimate strength according to modified Goodman relation will be

(a) 1100 MN/m<sup>2</sup>

(b) 1075 MN/m<sup>2</sup> ✓

(c) 1050 MN/m<sup>2</sup>

(d) 1025 MN/m<sup>2</sup>

31. In a Hartnell governor, the mass of each ball is 4 kg. The maximum and minimum centrifugal forces on the balls are 1800 N and 100 N at radii 25 cm and 20 cm, respectively. The lengths of vertical and horizontal arms of the bell-crank levers are the same. What is the spring stiffness?

- (a) 780 N/cm
- (b) 740 N/cm
- (c) 720 N/cm ✓
- (d) 680 N/cm

32. Consider the following statements regarding the ends of the pressure vessels flanged by pre-tensioned bolts :

1. Pre-tensioning helps to seal the pressure vessel.
2. Pre-tensioning reduces the maximum tensile stress in the bolts.
3. Pre-tensioning countermands the fatigue life of the bolts.
4. Pre-tensioning helps to reduce the deleterious effect of pressure pulsations in the pressure vessel.

Which of the above statements are correct?

- (a) 1, 2 and 3 only
- (b) 1, 3 and 4 only
- (c) 2 and 4 only
- (d) 1, 2, 3 and 4 ✓

33. Two shafts, one solid and the other hollow, made of the same material, will have the same strength and stiffness, if both are of the same

- (a) length as well as weight
- (b) length as well as polar modulus ✓
- (c) weight as well as polar modulus
- (d) length, weight as well as polar modulus

34. A solid shaft is to transmit 20 kW at 200 r.p.m. The ultimate shear stress for the shaft material is 360 MPa and the factor of safety is 8. The diameter of the solid shaft shall be

- (a) 42 mm ✓
- (b) 45 mm
- (c) 48 mm
- (d) 51 mm

35. In the 4-bar mechanism as shown, the link PQ measures 30 cm and rotates uniformly at 100 rev/min. The velocity of point Q on link PQ is nearly

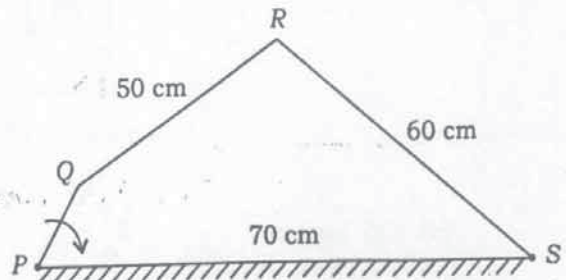

- (a) 2.54 m/s
- (b) 3.14 m/s ✓
- (c) 4.60 m/s
- (d) 5.80 m/s



36. The rim of a flywheel is subjected to
- (a) direct tensile stress and bending stress
  - (b) torsional shear stress and bending stress
  - (c) direct shear stress and bending stress
  - (d) compressive stress and bending stress

37. A stockist has to supply 400 units of a product every Monday to his customers. He gets the product at ₹ 50 per unit from the manufacturer. The cost of ordering and transportation from the manufacturer to the stockist's premises is ₹ 75 per order. The cost of carrying inventory is 7.5% per year of the cost of the product. What are the economic lot size and the total optimal cost (including capital cost) for the stockist?

- (a) 989 units/order and ₹ 20,065.80/week
- (b) 912 units/order and ₹ 20,065.80/week
- (c) 989 units/order and ₹ 18,574.50/week
- (d) 912 units/order and ₹ 18,574.50/week

38. Consider just only the following parameters :

- 1. Grinding wheel diameter
- 2. Regulating wheel diameter
- 3. Speed of grinding wheel
- 4. Speed of regulating wheel

Which of the above parameters will influence the axial feed rate in centreless grinding?

- (a) 2 and 4
- (b) 2 and 3
- (c) 1 and 3
- (d) 1 and 4

39. A metric thread of pitch 2 mm and thread angle  $60^\circ$  is inspected for its pitch diameter using the 3-wire method. The indicated diameter of the wire will be nearly

- (a) 0.85 mm
- (b) 1.05 mm
- (c) 1.15 mm
- (d) 2.05 mm

40. Consider the following statements with reference to NC machines :

- 1. Both closed-loop and open-loop systems are used.
- 2. Papers, tapes, floppy tapes and cassettes are used for data storage.
- 3. Digitizers may be used as interactive input devices.
- 4. Post-processor is an item of hardware.

Which of the above statements are correct?

- (a) 1, 2 and 4
- (b) 1, 3 and 4
- (c) 2, 3 and 4
- (d) 1, 2 and 3

41. Consider the following benefits of CIM :

1. Less direct labour ✓
2. Less scrap and rework
3. Higher machine use ✓

Which of the above are correct?

- (a) 1, 2 and 3
- (b) 1 and 2 only
- (c) 1 and 3 only
- (d) 2 and 3 only

42. A firm's inventory turnover of ₹ 8,00,000 is 5 times the cost of goods sold. If the inventory turnover is improved to 8 with the cost of goods sold remaining the same, a substantial amount of fund is either released from, or gets additionally invested in, inventory. Which one of the following statements is correct?

- ✓ (a) ₹ 1,60,000 is released.
- (b) ₹ 1,60,000 is additionally invested.
- ~~(c)~~ ₹ 60,000 is released. *60x2060*
- (d) ₹ 60,000 is additionally invested.

43. An 8-hour measurement study in a plant reveals that 320 number of units were produced. If idle time = 15% and performance rating = 120%, with allowance = 12% of normal time, the standard time per unit produced will be

- (a) 1.823 minutes
- (b) 1.714 minutes
- (c) 1.645 minutes ✓
- (d) 1.286 minutes

44. An organization's sales during a financial year is ₹ 6,00,000 with 90% of it on credit. At the end of the year, the receivables turnover was found to be 5. Considering 365 days to a year, the average collection period and receivables are, respectively.

- (a) 81 days and ₹ 1,08,000
- ✓ (b) 73 days and ₹ 1,08,000
- (c) 81 days and ₹ 1,20,000
- (d) 73 days and ₹ 1,20,000

45. A particular item has a demand of 9000 units/year. The cost of one procurement is ₹ 108 and the holding cost per unit is ₹ 2.40/year. The replacement is instantaneous and no shortages are allowed. What is the optimum number of orders/year?

- (a) 7 orders/year
- (b) 8 orders/year
- (c) 9 orders/year
- ✓ (d) 10 orders/year

46. Which one of the following is correct with respect to microcontrollers?

- ✓ (a) Integration of a microprocessor with I/O interfaces and memory and other peripherals in a single IC chip
- (b) A single very large scale integrated (VLSI) chip that contains programmable electronic components that perform control functions
- (c) Digital circuits for data handling and computation
- (d) The primary computation and system control operations

47. Which one of the following statements is correct?

Seismic transducer working in the displacement mode should have

- (a) weak springs and heavy mass
- (b) stiff springs and light mass ✓
- (c) weak springs and light mass
- (d) stiff springs and heavy mass

48. What will be the velocity of piston movement for a single-acting hydraulic actuator, when the fluid pressure is 100 bar, the diameter of the piston is 50 mm and the flow rate is  $0.3 \text{ m}^3/\text{min}$ ?

- (a) 2.41 m/s
- (b) 2.55 m/s
- (c) 2.67 m/s
- (d) 2.84 m/s ✓

$$P_f = \frac{Q}{A} \times 0.3$$

$$\frac{P_f}{50} \times 0.6 = 50 \times$$

49. A stepper motor is to be used to drive the linear axis of a certain Mechatronics system. The motor output shaft is connected to a screw thread with a 30 mm pitch. Linear resolution of 0.5 mm is stipulated. What is the needed step angle?

- (a)  $9^\circ$
- (b)  $8^\circ$
- (c)  $7^\circ$  ✓
- (d)  $6^\circ$

50. Consider the following statements regarding a stepper motor :

1. The rotation angle of the motor is proportional to the input pulse. ✓
2. The motor has full torque at standstill.
3. Speed and electric control signal of the motor vary mutually linearly.

Which of the above statements are correct?

- (a) 1 and 2 only
- (b) 1 and 3 only
- (c) 2 and 3 only
- (d) 1, 2 and 3 ✓

51. The following table lists the tasks in a project and the time duration for each task :

| Task | Preceding task | Normal duration (in weeks) |
|------|----------------|----------------------------|
| A    | —              | 16                         |
| B    | —              | 20                         |
| C    | A              | 8                          |
| D    | A              | 10                         |
| E    | B, C           | 6 ✓                        |
| F    | D, E           | 12                         |

$$\begin{array}{r} 46 \\ + 6 \\ \hline 50 \end{array}$$

The critical path, the project duration and the free float for activity A are, respectively

- (a) A-C-E-F; 42 weeks and 0 week
- (b) B-E-F; 42 weeks and 1 week ✓
- (c) B-C-D-F; 50 weeks and 2 weeks ✓
- (d) A-C-E-F; 50 weeks and 0 week

52. Consider the following statements with reference to SCARA Robot :

1. It has four degrees of freedom. ✓
2. It has only one forward kinematic solution.
3. It has two inverse kinematic solutions.

Which of the above statements are correct?

- (a) 1 and 2 only
- (b) 1 and 3 only
- (c) 2 and 3 only
- (d) 1, 2 and 3

53. Consider the following statements regarding the laws of Robotics :

1. A Robot shall not injure a human being or, through inaction, allow a human being harmed. ✓
2. A Robot must obey orders given by humans except when such orders conflict with first law. ✓
3. A Robot must always protect its own existence. ✓

Which of the above statements are correct?

- (a) 1 and 2 only
- (b) 1 and 3 only
- (c) 2 and 3 only
- (d) 1, 2 and 3 ✓

54. The number of degrees of freedom in a 3D Robot of TRL : R type configuration is

- (a) 4
- (b) 3 ✗
- (c) 2
- (d) 1 ✓

55. Which of the following are the basic differences between vibration signature and noise signature?

1. Vibration signature is essentially in the frequency range zero to 100 cps whereas noise signature is in the range 20 cps to 3000 cps.
2. Vibration signature has well-defined peaks whereas the noise signal is smeared.
3. The intensities of noise signatures are much less than that of vibration signatures.
4. Detection of vibration signature calls for a microphone whereas that of noise can do with a pickup.

Select the correct answer using the code given below.

- (a) 1 and 4
- (b) 2 and 3
- (c) 1 and 2
- (d) 3 and 4

56. Consider the following features relating to Robot kinematics with reference to SCARA Robot :

1. Shoulder and elbow rotational axes are vertical.
2. The Robot could perform insertion tasks along the vertical direction.
3. Its general configuration is analogous to that of a human arm.

Which of the above features are correct?

- (a) 1 and 2 only  
 (b) 1 and 3 only ✓  
 (c) 2 and 3 only  
 (d) 1, 2 and 3

57. A flywheel fitted to a steam engine has a mass of 500 kg and radius of gyration 300 mm. The starting torque is 900 N m. What is the kinetic energy after 10 s?

- (a) 225 kJ ✓  
 (b) 450 kJ  
 (c) 900 kJ  
 (d) 1800 kJ

$$K = \frac{1}{2} m v^2$$

$$= \frac{1}{2} \times m \times r^2 \times \omega^2$$

$$= \frac{1}{2} \times 500 \times \frac{300^2}{900} \times \frac{1}{3}$$

58. In a counterflow heat exchanger, hot gases enter at 250 °C and leave at 100 °C. Atmospheric air enters at 50 °C and leaves at 80 °C. The effectiveness of the heat exchanger will be

- (a) 0.20  
 (b) 0.25  
 (c) 0.30 ✓  
 (d) 0.35

$$\Rightarrow \frac{250 - 100}{80 - 50}$$

$$= \frac{150}{30} = 5$$

59. Two air streams with mass flow rates of 36 kg/min and 14 kg/min with respective enthalpies of 36 kJ/kg da and 50 kJ/kg da are mixed. The enthalpy of the mixture is nearly

- (a) 64 kJ/kg da  
 (b) 55 kJ/kg da  
 (c) 46 kJ/kg da ✓  
 (d) 40 kJ/kg da

$$\Rightarrow \frac{36 \times 36 + 14 \times 50}{36 + 14}$$

$$= \frac{1296 + 700}{50} = \frac{1996}{50} = 39.92$$

60. Consider the following statements in respect of maximum efficiency of a two-stage reciprocating compressor :

1. The pressure ratios are same for each stage.
2. The work done is same in each stage.  $\eta_{max} =$
3. The intercooling is perfect.

Which of the above statements are correct?

- (a) 1 and 2 only  
 (b) 1 and 3 only  
 (c) 2 and 3 only  
 (d) 1, 2 and 3 ✓

61. A section of a dam made of concrete,  $\rho = 2.6$ , total height = 35 m, with top walkway width of 6 m, is shown. The upstream bottommost point is called the Heel of the dam. The sloped part on downstream side is 3 vertical on 2 horizontal. Water stands till 2 m short of the top of the dam section. The net resultant force acting on the base level of the dam is nearly

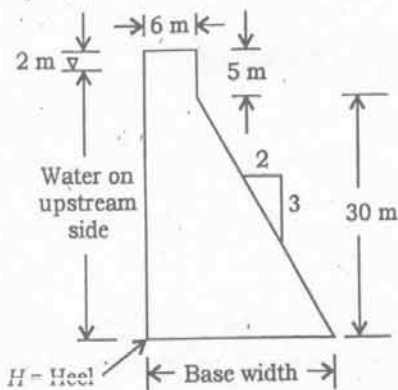

- (a) 1370 k kgf  
~~(b) 1385 k kgf~~  
 (c) 1400 k kgf  
 (d) 1433 k kgf

62. A spherical waterdrop of 1 mm in diameter splits up in air into 64 smaller drops of equal size. The surface tension coefficient of water in air is 0.073 N/m. The work required in splitting up the drop is

- ~~(a)  $0.96 \times 10^{-6}$  J~~  
 (b)  $0.69 \times 10^{-6}$  J  
 (c)  $0.32 \times 10^{-6}$  J  
 (d)  $0.23 \times 10^{-6}$  J

63. Consider the following statements pertaining to stability of floating bodies :

1. A floating body will be stable when the centre of gravity is above the centre of buoyancy.
2. The positions of metacentres corresponding to different axes of rotation are generally different for the same floating object.
3. For cargo ships, the metacentric height varies with loading.

Which of the above statements are correct?

- (a) 1, 2 and 3  
 (b) 1 and 2 only  
~~(c) 1 and 3 only~~  
 (d) 2 and 3 only

64. Water is coming out from a tap and falls vertically downwards. At the tap opening, the stream diameter is 20 mm with uniform velocity of 2 m/s. Assuming steady inviscid flow, constant pressure atmosphere everywhere, and neglecting curvature and surface tension effects, the diameter of the stream 0.5 m below the tap opening is nearly

- (a) 11.7 mm  
 (b) 14.6 mm  
 (c) 17.5 mm  
 (d)  $20.4$  mm ✓

65. Consider the following statements regarding Bernoulli's equation :

1. It is assumed that no energy has been supplied.
2. The velocity of a steady stream of fluid flow will depend on the cross-sectional area of the stream.
3. Consider two sections 1 and 2 along a flow stream. In this reach, if  $q$  is work done by a pump,  $w$  is work absorbed by turbine,  $\rho$  is density of water and  $g$  is acceleration of gravity, with  $p$ ,  $v$  and  $z$  carrying standard meanings, Bernoulli's equation will read

$$\frac{p_1}{\rho} + \frac{v_1^2}{2g} + z_1 = \frac{p_2}{\rho} + \frac{v_2^2}{2g} + z_2 + w + g$$

Which of the above statements are correct?

- (a) 1 and 2 only  
 (b) 1 and 3 only  
 (c) 2 and 3 only  
 (d) 1, 2 and 3

66. An oil flows through a pipe at a velocity of  $1.0 \text{ m/s}$ . The pipe is  $45 \text{ m}$  long and has  $150 \text{ mm}$  diameter. What is the head loss due to friction, if  $\rho = 869 \text{ kg/m}^3$  and  $\mu = 0.0814 \text{ kg/m s}$ ?

- (a)  $0.61 \text{ m}$  (b)  $0.51 \text{ m}$   
 (c)  $0.41 \text{ m}$  (d)  $0.31 \text{ m}$

67. Consider the following statements :

1. At low Reynolds numbers of any flow, viscous forces dominate over inertial forces.
2. Transition from laminar to turbulent flow occurs over a range of Reynolds numbers depending on the surface presented to the flow.

Which of the above statements is/are correct?

- (a) 1 only  
 (b) 2 only  
 (c) Both 1 and 2  
 (d) Neither 1 nor 2

68. In a steady laminar flow of a given discharge through a circular pipe of diameter  $D$ , the head loss is proportional to

- (a)  $D^{-1}$  (b)  $D^{-2}$   
 (c)  $D^{-3}$  (d)  $D^{-4}$

69. A two-dimensional flow field is defined as  $\vec{V} = \vec{i}x - \vec{j}y$ . The equation of the streamline passing through the point  $(1, 2)$  is

- (a)  $xy + 2 = 0$   
 (b)  $x^2y + 2 = 0$   
 (c)  $xy - 2 = 0$   
 (d)  $x^2y - 2 = 0$

$v = ix - jy$   
 $\partial u = x^2 - y^2$

70. The centre-line velocity in a pipe flow is  $2 \text{ m/s}$ . What is the average flow velocity in the pipe if the Reynolds number of the flow is 800?

- (a)  $2 \text{ m/s}$  (b)  $1.5 \text{ m/s}$   
 (c)  $1 \text{ m/s}$  (d)  $0.5 \text{ m/s}$

71. During a constant pressure expansion of a gas,  $33.3\%$  heat is converted into work while the temperature rises by  $20 \text{ K}$ . The specific heat of the gas at constant pressure as a proportion of work,  $W$  is

- (a)  $8\%$  (b)  $10\%$   
 (c)  $12\%$  (d)  $15\%$

$q = 33.3\% \text{ } W$   
 $20 \text{ K}$

72. A cylinder contains  $10 \text{ m}^3$  of an ideal gas at a pressure of 2 bar. This gas is compressed in a reversible isothermal process till its pressure increases to 15 bar. What quantum of work will be required for this process? (You can use the table given herewith.)

| Number      | 2     | 2.5   | 3     | 5     | 7     |
|-------------|-------|-------|-------|-------|-------|
| $\log_{10}$ | 0.301 | 0.397 | 0.475 | 0.698 | 0.845 |

- (a) 4500 kJ      (b) 4030 kJ  
 (c) 450 kJ ✓      (d) 403 kJ

73. A system of 100 kg mass undergoes a process in which its specific entropy increases from  $0.3 \text{ kJ/kg K}$  to  $0.4 \text{ kJ/kg K}$ . At the same time, the entropy of the surroundings decreases from  $80 \text{ kJ/kg K}$  to  $75 \text{ kJ/kg K}$ . The process is

- (a) reversible and isothermal ✓  
 (b) irreversible  
 (c) reversible only  
 (d) isothermal only

74. A reversible heat engine rejects 80% of the heat supplied during a cycle of operation. If the engine is reversed and operates as a refrigerator, then its coefficient of performance shall be

- (a) 6                      (b) 5  
 (c) 4 ✓                    (d) 3

75. For the same efficiency of the Brayton cycle and the Carnot cycle working between temperature limits of  $T_{\text{max}}$  and  $T_{\text{min}}$ , the power contribution of the Brayton cycle will be

- (a) zero  
 (b) maximum  
 (c) minimum  
 (d) 50% of the Carnot cycle ✓

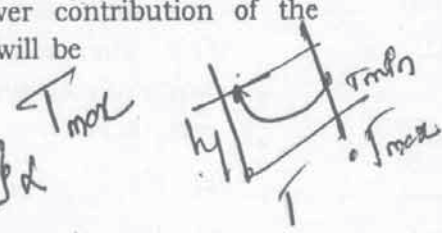

76. The thermal efficiency of the hypothetical cycle shown is

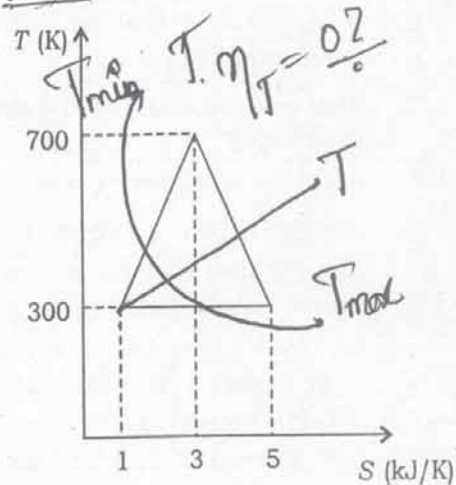

- (a) 0.6                      (b) 0.5  
 (c) 0.4 ✓                    (d) 0.3

77. A heat engine working on the Carnot cycle receives heat at the rate of  $50 \text{ kW}$  from a source at  $1300 \text{ K}$  and rejects it to a sink at  $400 \text{ K}$ . The heat rejected is

- (a)  $20.3 \text{ kW}$   
 (b)  $15.4 \text{ kW}$   
 (c)  $12.4 \text{ kW}$   
 (d)  $10.8 \text{ kW}$

Handwritten calculation:  
 $50 \text{ kW}$   
 $T_1 = 1300 \text{ K}$   
 $T_2 = 400 \text{ K}$   
 $\frac{Q_1}{Q_2} = \frac{T_1}{T_2}$   
 $\frac{50}{Q_2} = \frac{1300}{400}$   
 $Q_2 = \frac{50 \times 400}{1300} = 15.4 \text{ kW}$

78. An ideal gas is flowing through an insulated pipe at the rate of  $3.3 \text{ kg}$ . There is a pressure drop of  $15\%$  from the inlet to the outlet of the pipe. What is the rate of energy loss because of this pressure drop due to friction, given that  $R_{\text{gas}} = 0.287 \text{ kJ/kg K}$  and the reference temperature  $T_0$  is  $300 \text{ K}$ ?

- (a)  $42.62 \text{ kW}$   
 (b)  $40.26 \text{ kW}$   
 (c)  $38.14 \text{ kW}$   
 (d)  $35.13 \text{ kW}$  ✓

Handwritten calculation:  
 $R_{\text{gas}} = 0.287$



79. A furnace is provided with an insulating refractory lining. The overall thermal conductivity of the material is  $0.03 \text{ W/m K}$ . The thickness of the lining is  $100 \text{ mm}$ . The inner and outer temperatures are  $250^\circ\text{C}$  and  $50^\circ\text{C}$ , respectively. The heat loss to the surroundings will be

- ~~(a)~~  $30 \text{ J/m}^2/\text{s}$
- (b)  $60 \text{ J/m}^2/\text{s}$
- (c)  $60 \text{ J/s}$
- (d)  $30 \text{ J/s}$

80. A wall of  $0.6 \text{ m}$  thickness has normal area of  $1.5 \text{ m}^2$  and is made up of material of thermal conductivity  $0.4 \text{ W/m K}$ . If the temperatures on the two sides of the wall are  $800^\circ\text{C}$  and  $1000^\circ\text{C}$ , the thermal resistance of the wall is

- (a)  $1.8 \text{ K/W}$
- ~~(b)~~  $1.8 \text{ W/K}$
- (c)  $1 \text{ K/W}$
- (d)  $1 \text{ W/K}$

$\gamma = 0.6$   
 $A = 1.5$   
 $T_{\text{temp}} = 0.4$   
 $T = 1000$

81. Heat is lost from a  $100 \text{ mm}$  diameter steam pipe placed horizontally in ambient air at  $30^\circ\text{C}$ . If the Nusselt number is  $25$  and the thermal conductivity of the air is  $0.03 \text{ W/m K}$ , then the heat transfer coefficient will be

- ~~(a)~~  $7.5 \text{ W/m}^2 \text{ K}$
- (b)  $15 \text{ W/m}^2 \text{ K}$
- (c)  $25 \text{ W/m}^2 \text{ K}$
- (d)  $35 \text{ W/m}^2 \text{ K}$

$D_1 = 100$   
 $\sin \theta = 30^\circ$   
 $N = 25$   
 $T = 0.03$   
 $= \frac{4}{100} \times \frac{25 \times 0.03}{3}$

82. Air at 1 atmospheric pressure and  $27^\circ\text{C}$  blows across a  $12 \text{ mm}$  diameter sphere at a free stream velocity of  $4 \text{ m/s}$ . A small heater inside the sphere maintains the surface temperature at  $77^\circ\text{C}$ . With  $k = 0.026 \text{ W/m (kelvin)}$  and with  $(Nu) = 31.4$ , the heat loss by the sphere would be

- ~~(a)~~  $1.93 \text{ J/s}$  (b)  $1.76 \text{ J/s}$
- (c)  $1.65 \text{ J/s}$  (d)  $1.54 \text{ J/s}$

83. The view factors  $F_{12}$  and  $F_{21}$ , for the sphere of diameter  $d$  and a cubical box of length  $l = d$  as shown in the figure, respectively, are

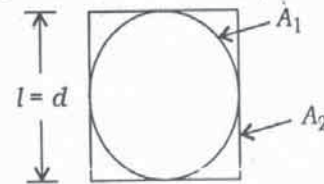

- (a)  $1$  and  $\frac{\pi}{3}$  (b)  $\frac{\pi}{3}$  and  $1$  ✓
- (c)  $1$  and  $\frac{\pi}{6}$  (d)  $\frac{\pi}{6}$  and  $1$

84. Knocking in a spark ignition engine can be reduced by

1. retarding the spark
2. supercharging
3. increasing the engine speed
4. using a fuel of long straight chain structure

Select the correct answer using the code given below.

- (a) 1 and 4
- ~~(b)~~ 1 and 3
- ~~(c)~~ 2 and 3
- (d) 2 and 4

85. A 4-cylinder diesel engine running at 1200 r.p.m. developed 18.6 kW. The average torque when one cylinder was cut out was 105 N m. If the calorific value of the fuel was 42000 kJ/kg and the engine used 0.34 kg of diesel/kW hr, the indicated thermal efficiency was nearly

- (a) 29%      (b) 26%  
 (c) 31%      (d) 23%

86. In a Morse test on a 2-cylinder, 2-stroke SI engine, the brake power is 9 kW and the BHP of individual cylinders with spark cutoff are 4.25 kW and 3.75 kW, respectively. The mechanical efficiency of the engine is

- (a) 90%      (b) 80%  
 (c) 52.5%      (d) 45.5%

87. The ordinates and abscissae of the diagram given for the vapour-compression refrigeration cycle represent

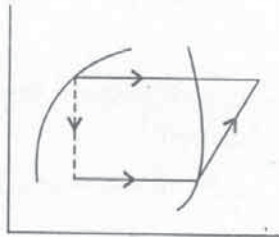

- (a) pressure and volume  
 (b) temperature and entropy  
 (c) enthalpy and entropy  
 (d) pressure and enthalpy

88. Consider the following statements for refrigeration and air-conditioning :

- In a refrigerating machine, the heat exchanger that absorbs heat is connected to a conditioned space.

- A refrigerating cycle operating reversibly between two heat reservoirs has the highest coefficient of performance.
- The lower the refrigeration required and the higher the temperature of heat rejection to the surroundings, the larger the power consumption.

Which of the above statements are correct?

- (a) 1 and 2 only  
 (b) 1 and 3 only  
 (c) 2 and 3 only  
 (d) 1, 2 and 3

89. In a refrigerator, the evaporator and condenser coil temperatures are  $-33^{\circ}\text{C}$  and  $27^{\circ}\text{C}$ , respectively. Assuming that the maximum COP is realized, the required power input for a refrigerating effect of 4 kW is

- (a) 8 kW      (b) 4 kW  
 (c) 2 kW      (d) 1 kW

90. Consider the following statements :

The volumetric efficiency of a reciprocating compressor can be improved by

- decreasing the clearance volume
- cooling the intake air
- heating the intake air

Which of the above statements is/are correct?

- (a) 2 only  
 (b) 3 only  
 (c) 1 and 2  
 (d) 1 and 3

Directions :

Each of the following **thirty (30)** items consists of two statements, one labelled as 'Statement (I)' and the other as 'Statement (II)'. Examine these two statements carefully and select the answers to these items using the code given below :

Code :

- (a) Both Statement (I) and Statement (II) are individually true and Statement (II) is the correct explanation of Statement (I)
- (b) Both Statement (I) and Statement (II) are individually true but Statement (II) is **not** the correct explanation of Statement (I)
- (c) Statement (I) is true but Statement (II) is false
- (d) Statement (I) is false but Statement (II) is true

91. Statement (I) :

(d) Depth of centre of pressure of any immersed surface is independent of the density of the liquid.

Statement (II) :

Centre of area of the immersed body lies below the centre of pressure.

92. Statement (I) :

✓ In flow through a pipeline, the nature of the fluid flow depends on the velocity of the fluid.

(b) Statement (II) :

Reynolds number of the flow depends on the velocity, the diameter of the pipe and the kinematic viscosity of the fluid.

93. Statement (I) :

✓ The specific heat at constant pressure for an ideal gas is always greater than the specific heat at constant volume.

(d) Statement (II) :

✓ Heat added at constant volume is not utilized for doing any external work.

94. Statement (I) :

(d) A homogeneous mixture of gases that do not react within themselves can be treated as a pure substance.

Statement (II) :

Flue gases can be treated as a homogeneous mixture of gases.

95. Statement (I) :

(d) Air-blast injection in diesel engines could reduce engine efficiency.

Statement (II) :

Air-blast injection in diesel engines is not instantaneous but happens when the piston moves outward with the injection valve remaining open for whatever reason.

96. Statement (I) :

(c) Use of non-azeotropic mixtures used as the refrigerant in a vapour-compression system improves the coefficient of performance.

Statement (II) :

The increase in this coefficient is attributable to reduction in volume.

97. Statement (I) :

(a) Sub-cooling of a refrigerant liquid increases the coefficient of performance of a refrigeration cycle.

Statement (II) :

Sub-cooling reduces the work requirement of the refrigeration cycle.

98. Statement (I) :

In vapour-absorption system, larger the value of specific solution circulation, more the pump work.

Statement (II) :

(c) Higher solution circulation rates of poor as well as rich solutions need larger pressure drops in the system.

99. Statement (I) :

Outward radial flow turbines do race inherently.

Statement (II) :

(d) In outward radial flow turbines, the centrifugal head impressed upon the exiting water leads to flow increase.

100. Statement (I) :

Regarding the power transmitted by a clutch, greater the speed, lower the torque to be transmitted for fixed power rating. ✓

Statement (II) :

(b) The clutch is placed on the low-speed side to transmit larger torque. ✓

101. Statement (I) :

✓ The volume of air taken into the cylinder of a reciprocating air compressor is less than the stroke volume of the cylinder.

(d) Statement (II) :

✓ Air that has been compressed to clearance volume expands to larger volumes during the suction stroke.

102. Statement (I) :

Providing reheat in a Rankine cycle would increase the efficiency of the cycle.

Statement (II) :

Reheat in Rankine cycle reduces specific steam consumption.

103. Statement (I) :

(d) Heat carried away by hot gases in chimney draught is much greater than the work required for lifting the same gases through the height of the chimney. Yet artificial draught is not preferred.

Statement (II) :

Artificial draught involves large initial cost as well as large maintenance cost.

104. Statement (I) :

(a) The overall combustion efficiency of a fuel oil based plant is less as compared to that of a coal burning plant.

Statement (II) :

✓ Fuel oils contain comparatively larger percentage of hydrogen, which produce more moisture per kg of fuel burnt.

105. Statement (I) :

Proximate analysis of coal is done to determine its calorific value.

Statement (II) : (d)

In proximate analysis of coal, the percentages of moisture, volatile matter, fixed carbon and ash are determined.

106. Statement (I) :

Water entering into a condenser from the cooling tower has much dissolved impurities.

Statement (II) :

(a) In a closed cooling system, the water is continuously aerated, therefore, there is abundant dissolved oxygen in this water.

107. Statement (I) :

Pyranometer is used to measure diffuse solar radiation by blocking the direct radiation with a shadow band.

Statement (II) :

(b) Pyrheliometer is used to measure diffuse radiation.

108. Statement (I) :

Directionally solidified materials have good creep resistance.

Statement (II) :

(c) Directionally solidified materials may be so loaded that there is no shearing stress along, or tensile stress across, the grain boundaries.

109. Statement (I) :

(a) The ideal material for shafts transmitting power is CI.

Statement (II) :

CI resists compression well.

110. Statement (I) :

Hardenability curves are developed based on the fact that any given steel item always develops the same microstructure under a standardized cooling rate.

Statement (II) : (b)

Industry employs Jominy hardenability test to measure hardenability.

111. Statement (I) :

(b) Cams used in high-speed application should have displacement, velocity and acceleration curves of the follower in continuity. ✓

Statement (II) :

Abrupt changes in these curves will cause high contact stresses at the bearings and make the operation noisy.

112. Statement (I) :

Resonance is a special case of forced vibration in which the natural frequency of the body is the same as the impressed frequency of the external periodic force whereby the amplitude of the forced vibration peaks sharply. (c)

Statement (II) :

The amplitude of forced vibration of a body increases with increase in the frequency of the externally impressed periodic force.

113. Statement (I) :

All worm drives (worm and worm wheel) are reversible.

Statement (II) :

The worm and worm wheel are made of different materials. (a)

114. Statement (I) :

There is no balancing methodology in the case of reciprocating engines. ✓

Statement (II) :

Balancing of dynamic forces is achieved mostly by resorting to multi-cylinder engine concept. (a)

115. Statement (I) :

Two circular discs of equal masses and thickness made of different materials will have same moment of inertia about their central axes of rotation.

Statement (II) :

Moment of inertia depends upon the distribution of mass within the body. ✓

(b)

116. Statement (I) :

The speed of a governed water turbine will remain constant irrespective of load.

Statement (II) :

In governing, the water supply is regulated to maintain the speed constant.

117. Statement (I) :

In sugarcane crushing rollers, the fit between the cast roll and the forged steel shaft is of interference type.

Statement (II) :

This helps in removing the roll from the shaft whenever not needed. (b)

118. Statement (I) :

Thicker sections of casting take longer to solidify than thinner sections.

Statement (II) :

(b) Thicker sections of casting carry residual stresses.

119. Statement (I) :

Sand with grains of uniform round shape is preferred for preparing moulds.

Statement (II) :

If grains are large and regular in shape, the air-venting property of the mould prepared with them would be better.

120. Statement (I) :

Bar chart plots in the time dimension the planned performance of various activities of a project.

Statement (II) :

(c) One advantage of a bar chart is that the inter se sequence and linkage of all activities is indicated therein.

121. Consider the following statements :

The presence of air inside condensers

1. remains as a non-condensable gas
2. reduces the condensing coefficient
3. tends to cling to the surface ✓
4. introduces large thermal resistance ✓

Which of the above statements are correct?

- (a) 1, 2, 3 and 4
- (b) 1, 2 and 3 only
- (c) 3 and 4 only ✓
- (d) 1, 2 and 4 only

122. The refrigeration system of an ice plant working between temperatures of  $-5^{\circ}\text{C}$  and  $25^{\circ}\text{C}$  produces 20 kg of ice per minute from water at  $20^{\circ}\text{C}$ . The specific heat of water is  $4.2\text{ kJ/kg}$  and latent heat of ice is  $335\text{ kJ/kg}$ . The refrigeration capacity of the refrigeration plant is

- (a) 9040 kJ/min
- (b) 8750 kJ/min ✓
- (c) 8380 kJ/min
- (d) 8010 kJ/min

123. Consider the following statements in respect of a vapour-absorption refrigeration cycle :

1. The absorption refrigeration cycle is generally used when waste heat is available from an existing source or when free energy like solar energy is to be used.
2. There are no moving parts in the absorption refrigeration plant except a small liquid pump.

3. The value of the coefficient of performance is nearly the same in both vapour-absorption and vapour-compression refrigeration plants.

Which of the above statements are correct?

- (a) 1, 2 and 3 ✓
- (b) 1 and 2 only
- (c) 1 and 3 only
- (d) 2 and 3 only ✓

124. Air at  $30^{\circ}\text{C}$  and 1 bar has a specific humidity of  $0.016\text{ kg/kg}$  of dry air. By considering the saturation pressure of water vapour at  $30^{\circ}\text{C}$  as  $4.246\text{ kPa}$ , the relative humidity of the air will be

- (a) 66.1%
- (b) 60.2%
- (c) 58.8%
- (d) 56.8% ✓

125. Consider the following statements in respect of an evaporative cooling process :

1. The wet-bulb temperature remains constant.
2. The dew-point temperature remains constant.
3. The enthalpy remains constant.

Which of the above statements are correct?

- (a) 1, 2 and 3
- (b) 1 and 2 only ✓
- (c) 2 and 3 only ✓
- (d) 1 and 3 only

126. For a steady process, the conditions at stage 1 and stage 2 are, respectively,  $h_1 = 300$  kJ/kg,  $h_2 = 150$  kJ/kg,  $S_1 = 1.25$  kJ/kg K and  $S_2 = 0.8$  kJ/kg K. The 'availability' at the ambient temperature 300 K will be

~~(a)~~ 15 kJ

(b) 20 kJ

(c) 25 kJ

(d) 35 kJ

$T = 300K$

127. If the maximum pressure in both air-standard Otto and Diesel cycles is the same, then the relations for compression ratio  $r$  and the efficiency  $\eta$  between the two cycles are

(a)  $r_{\text{Diesel}} > r_{\text{Otto}}$  and  $\eta_{\text{Diesel}} > \eta_{\text{Otto}}$

(b)  $r_{\text{Otto}} > r_{\text{Diesel}}$  and  $\eta_{\text{Diesel}} > \eta_{\text{Otto}}$

(c)  $r_{\text{Diesel}} > r_{\text{Otto}}$  and  $\eta_{\text{Otto}} > \eta_{\text{Diesel}}$

~~(d)~~  $r_{\text{Otto}} > r_{\text{Diesel}}$  and  $\eta_{\text{Otto}} > \eta_{\text{Diesel}}$

128. Which of the following statements are correct?

1. The specific speed of a turbine is the speed at which a homologous turbine develops 1 mhp under unit head at its maximum efficiency.

2. The specific speed is a dimensionless parameter used for the selection of turbines.

3. The function of guide vanes in reaction turbines is to minimize shock at entry of the fluid onto the runner blades.

Select the correct answer using the code given below.

(a) 1, 2 and 3

~~(b)~~ 2 and 3 only ✓

(c) 1 and 2 only ✓

(d) 1 and 3 only

129. A centrifugal pump lifts  $0.0125$  m<sup>3</sup>/s of water from a well with a static lift of 30 m. If the brake power of the driving electric motor is 5 kW, what is the overall efficiency of the pump-set?

~~(a)~~ 57.6%

(b) 63.9%

(c) 65.3%

~~(d)~~ 73.6%

$\eta = 57\% + 28\%$

130. Two rods, one of length  $l$  and the other of length  $2l$ , are made of the same material and have same diameter. Both ends of the longer rod are maintained at  $100^\circ\text{C}$ . One end of the shorter rod is maintained at  $100^\circ\text{C}$  while the other end is insulated. Both rods are exposed to the same environment at  $40^\circ\text{C}$ . The temperature at the insulated end is measured to be  $55^\circ\text{C}$ . The temperature at the midpoint of the longer rod would be

~~(a)~~  $45^\circ\text{C}$

(b)  $50^\circ\text{C}$

(c)  $55^\circ\text{C}$

(d)  $60^\circ\text{C}$

$\frac{0.5 \times 100}{100 - 40} = \frac{0.5 \times 100}{50}$



131. Consider the following statements in respect of ideal and practical gas turbine cycles :

1. In the ideal cycle case, the cycle efficiency depends on the pressure ratio only.
2. In the practical cycle case (with irreversibilities in the compression and expansion processes), the cycle efficiency depends on the maximum temperature as well as on the pressure ratio.
3. In the practical cycle case, at a given maximum temperature, the maximum efficiency and the maximum work done occur at a same pressure ratio.

Which of the above statements are correct?

- (a) 1 and 2 only
- (b) 1 and 3 only
- (c) 2 and 3 only
- (d) 1, 2 and 3

132. A jet of water issues from a sharp-edged vertical orifice under a constant head of 0.51 m. At a certain point of the issuing jet, the horizontal and vertical coordinates measured from vena contracta are 0.406 m and 0.085 m, respectively. What is the value of the coefficient of velocity?

- (a) 0.975
- (b) 0.925
- (c) 0.875
- (d) 0.825

133. In the working of a vapour-compression refrigeration plant, the following enthalpies are recorded at salient points in the cycle :

1. Enthalpy at inlet to compressor (saturated vapour),  $h_1 = 300$  kJ/kg
2. Enthalpy at outlet of compressor (after isentropic compression),  $h_2 = 330$  kJ/kg
3. Enthalpy at exit of condenser (saturated liquid),  $h_3 = 150$  kJ/kg

What is the COP of the plant?

- (a) 3
- (b) 4
- (c) 5
- (d) 6

134. Consider the following statements for single-stage reciprocating compressors :

1. Isothermal process is the most desirable process for compression.
2. The size of clearance volume provided in the compressor has no effect on work done per kg of air delivered.
3. The volumetric efficiency of the compressor decreases with increasing pressure.

Which of the above statements are correct?

- (a) 1 and 2 only
- (b) 1 and 3 only
- (c) 2 and 3 only
- (d) 1, 2 and 3

135. Consider the following statements in respect of regenerative Rankine cycle :

1. Regeneration increases the efficiency of the cycle ✓
2. The boiler capacity is increased for a given output.
3. The capacity of the condenser is reduced. ✓

Which of the above statements are correct?

- (a) 1, 2 and 3
- (b) 1 and 2 only
- (c) 1 and 3 only
- (d) 2 and 3 only

136. Consider the following statements in respect of (l) the temperature of the medium, (m) the refrigerant and (n) the condenser and absorption system—in a refrigeration unit :

1. Temperature of the medium being cooled must be below that of the evaporator.
2. Refrigerant leaves the condenser as liquid.
3. Any solar thermally operated absorption system is capable only of intermittent operation.

Which of the above statements are correct?

- (a) 1 and 2 only
- (b) 1 and 3 only
- (c) 2 and 3 only
- (d) 1, 2 and 3

137. Volumetric analysis of a certain flue gas gave CO<sub>2</sub> 15%, O<sub>2</sub> 5% and rest as N<sub>2</sub>. The gas was at a temperature of 200 °C and a pressure of 5 bar. The partial pressure of N<sub>2</sub> in the flue gas is

- (a) 250 kN/m<sup>2</sup>
- (b) 300 kN/m<sup>2</sup>
- (c) 350 kN/m<sup>2</sup>
- ~~(d)~~ 400 kN/m<sup>2</sup>

138. Consider the following statements :

1. The efficiency of heat transfer in a condenser will improve by increase of the overall heat transfer coefficient.
2. The efficiency of heat transfer in a condenser will improve by increase of the velocity of flow of water in the tube.
3. The difference between the temperature of steam entering the condenser and the inlet water temperature should be maximum for maximum efficiency.

Which of the above statements are correct?

- (a) 1 and 2 only
- (b) 1 and 3 only
- (c) 2 and 3 only
- (d) 1, 2 and 3 ✓

139. The total power developed by a three-stage velocity compounded impulse steam turbine is 900 kW. The power magnitudes developed in the first and the second stages are, respectively

- (a) 500 kW and 300 kW
- (b) 100 kW and 300 kW
- (c) 500 kW and 100 kW
- (d) 100 kW and 100 kW

140. Consider the following statements in respect of natural-draft cooling towers :

1. Theoretically the water can be cooled to even below the dry-bulb temperature of the induced air flow.
2. Natural-draft cooling towers are 100 m or more in height.
3. The inner and outer surfaces are surfaces of revolution of a segment of a hyperbola about the vertical axis—affording improved strength rather than any thermodynamic augmentation.

Which of the above statements are correct?

- (a) 1, 2 and 3
- (b) 1 and 2 only
- (c) 1 and 3 only
- (d) 2 and 3 only

141. Consider the following statements :

1. Wind velocity at about 20 m height above the ground is taken as the rated velocity for design of wind-mills.
2. The total power of a wind stream is directly proportional to the cube of average velocity.

3. Wind turbine operates with variable load over a narrow range between cut-in and cut-out velocities.
4. Vertical wind machine operates in all wind directions, but it needs yaw adjustment.

Which of the above statements are correct?

- (a) 1 and 2
- (b) 1 and 4
- (c) 3 and 4
- (d) 2 and 3

142. Which fuel cell is suitable for spacecraft applications?

- (a) Direct methanol fuel cell
- (b) Proton exchange membrane fuel cell
- (c) Alkaline fuel cell
- (d) Phosphoric acid fuel cell

143. A flywheel on a motor speeds up from rest to 1000 r.p.m. in 6 seconds. The number of revolutions made thereby is nearly

- (a) 200
- (b) 100
- (c) 50
- (d) 20

144. Two steel balls of 2 kg and 4 kg mass, respectively, are pressed on the two ends of a spring, all pre-placed on a smooth surface. When released, the smaller ball moves with an acceleration of  $2 \text{ m/s}^2$ . The simultaneous acceleration of the bigger ball will be

- (a)  $0.5 \text{ m/s}^2$
- (b)  $1 \text{ m/s}^2$
- (c)  $2 \text{ m/s}^2$
- (d)  $4 \text{ m/s}^2$

145. A bullet of mass 0.03 kg moving with a speed of 400 m/s penetrates 12 cm into a fixed block of wood. The average force exerted by the wood on the bullet will be

- (a) 30 kN
- ~~(b) 20 kN~~
- (c) 15 kN
- (d) 10 kN

146. A ball of weight 100 N is tied to a smooth wall by a cord making an angle of  $30^\circ$  to the wall. The tension in the cord is

- (a) 200 N
- (b)  $\frac{200}{\sqrt{3}}$  N
- ~~(c) 100 N~~
- (d)  $50\sqrt{3}$  N

147. The modulus of rigidity of an elastic material is found to be 38.5% of the value of its Young's modulus. The Poisson's ratio  $\mu$  of the material is nearly

- (a) 0.28
- (b) 0.30
- (c) 0.33 ✓
- (d) 0.35

148. A bar produces a lateral strain of magnitude  $60 \times 10^{-5}$  m/m when subjected to a tensile stress of magnitude 300 MPa along the axial direction. What is the elastic modulus of the material if the Poisson's ratio is 0.3?

- (a) 200 GPa
- ~~(b) 150 GPa~~
- (c) 125 GPa
- (d) 100 GPa

149. In the design of beams for a given strength, consider that the conditions of economy of use of the material would avail as follows :

1. ✓ Rectangular cross-section is more economical than square section of the same cross-sectional area of the beam.
2. Circular section is more economical than square section.
3. I-section is more economical than a rectangular section of the same depth.

Which of the above are correct?

- (a) 1, 2 and 3 •
- (b) 1 and 2 only
- (c) 2 and 3 only
- (d) 1 and 3 only

150. Which one of the following statements is correct?

- (a) The strain produced per unit volume is called resilience.
- (b) The maximum strain produced per unit volume is called proof resilience.
- (c) The least strain energy stored in a unit volume is called proof resilience.
- (d) The greatest strain energy stored in a unit volume of a material without permanent deformation is called proof resilience.