

ELECTRICAL ENGINEERING
Paper I

Time Allowed : Three Hours

Maximum Marks : 300

QUESTION PAPER SPECIFIC INSTRUCTIONS

Please read each of the following instructions carefully before attempting questions.

There are **EIGHT** questions divided in **TWO** Sections.

Candidate has to attempt **FIVE** questions in all.

Question Nos. **1** and **5** are **compulsory** and out of the remaining, **THREE** are to be attempted choosing at least **ONE** question from each Section.

The number of marks carried by a question/part is indicated against it.

Answers must be written in the medium authorized in the Admission Certificate which must be stated clearly on the cover of this Question-cum-Answer (QCA) Booklet in the space provided. No marks will be given for answers written in medium other than the authorized one.

Assume suitable data, if considered necessary and indicate the same clearly.

Unless otherwise mentioned, symbols and notations carry their usual standard meanings.

Attempts of questions shall be counted in sequential order. Unless struck off, attempt of a question shall be counted even if attempted partly. Any page or portion of the page left blank in the Question-cum-Answer Booklet must be clearly struck off.

SECTION 'A'

1.(a) Find $y(0.75)$ by applying Euler's method to the initial value problem

$$\frac{dy}{dx} = 2\cos\left(\frac{4\pi x}{3}\right) - y, \quad y(0) = 1. \quad \text{Take step size } h = 0.25.$$

12

1.(b) Four charges $q_1 = -2.0 \times 10^{-9}$ Coulomb, $q_2 = 3.0 \times 10^{-9}$ Coulomb, $q_3 = 2.0 \times 10^{-9}$ Coulomb and $q_4 = 1.0 \times 10^{-9}$ Coulomb are placed at four corners of a square of 2.0 metre side. Find out the potential at the centre of the square.

12

- 1.(c)
- (i) Discuss the biasing conditions of $p-n$ junctions in a Bipolar Junction transistor under saturation and cut off conditions.
 - (ii) Determine whether the transistor circuit shown can be termed as being saturated.

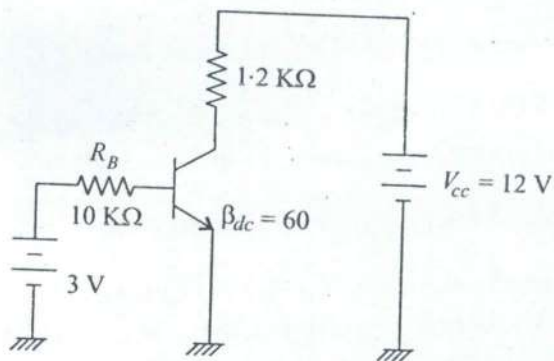

- (iii) Draw the variation of space charge, electric field and electrostatic potential across a semiconductor $p-n$ junction. 4+4+4=12

1.(d) Two parallel plates are separated 0.25 cm apart. The gap is partially filled with 0.23 cm thick sheet of fibre with $\epsilon_r = 5$. A potential difference of 2.5 KV is applied across the plate. Determine the electric field strength in the fibre and air film between the fibre and the plate. Will the air break down? Dielectric strength of air can be taken as 30 KV/cm.

12

- 1.(e)
- (i) What is meant by the term pinch off voltage of a JFET? Draw the drain characteristics of a JFET for $V_{GS} = 0$ V & show the pinch off voltage in the diagram.
 - (ii) Define the terms transconductance and amplification factor of a JFET.
 - (iii) In an FET, as V_{GS} , the gate-to-source voltage is varied from -1.5 V to -2 V, keeping V_{DS} constant, I_D of an FET decreases from 7.5 mA to 5.5 mA. What is the transconductance of the FET? If the a.c. drain resistance is 210 kilo ohms, find the amplification factor. 4+4+4=12

- 2.(a) Find the *absolute* maximum and minimum values of the function $f(x, y) = x^2 + 3y^2 - y$ over the region $x^2 + 2y^2 \leq 1$.

20

- 2.(b) Find the current flowing through the $6\ \Omega$ resistor in the circuit shown using Thevenin's theorem. Find also the power delivered to it.

20

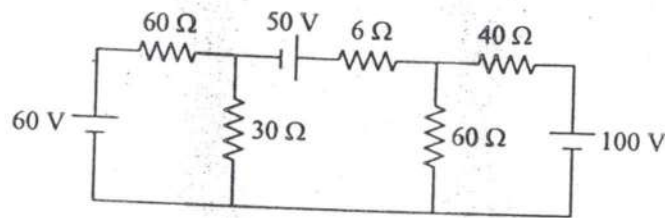

- 2.(c) (i) For the common emitter amplifier shown, find the values of the collector current I_C and V_{CE} if $\beta_{dc} = 150$.

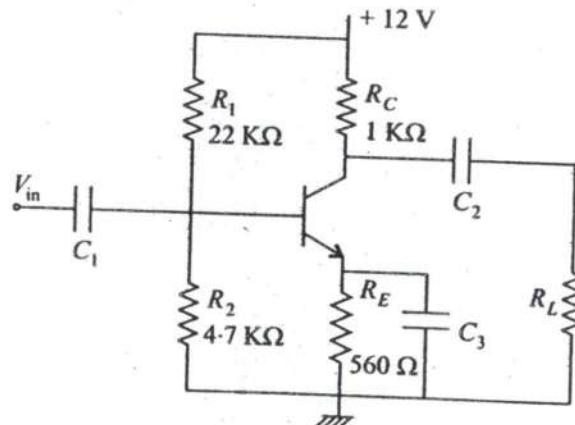

- (ii) Draw the a.c. equivalent circuit of the base of the transistor amplifier. Find the value of the input resistance and the voltage gain. Discuss the effect of the capacitor C_3 on the voltage gain when $V_{in} = 10\text{ mV}$. (Please refer to amplifier circuit above)

8+12=20

- 3.(a) Find the volume enclosed between the surfaces $x^2 + y^2 + z^2 = 16$ and $x^2 + y^2 - 4x = 0$.

20

3.(b) A circuit is shown.

- (i) Determine the value of the reactance X which makes the source current in phase with the source voltage.
- (ii) Compute also the effective value of the current for the condition described in part (i).

20

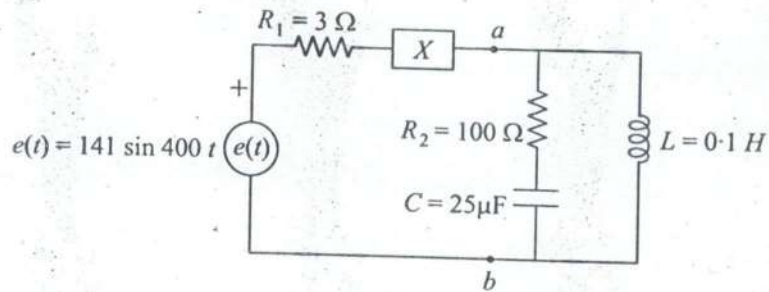

- 3.(c) (i) Find the minimum voltage gain and input resistance of the amplifier ($g_m = 2100 \mu$ Siemens) for the circuit of the JFET amplifier as shown in figure.

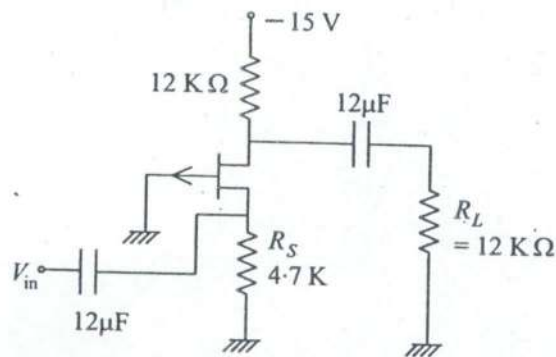

- (ii) Find the value of the lower cut off frequency for the MOSFET amplifier depicted in figure. Assume $C_1 = 0.001 \mu F$, $R_G = 10 M \Omega$, $R_D = 4.7 K$, $I_{GSS} = 25 nA @ V_{GS} = -10 V$.

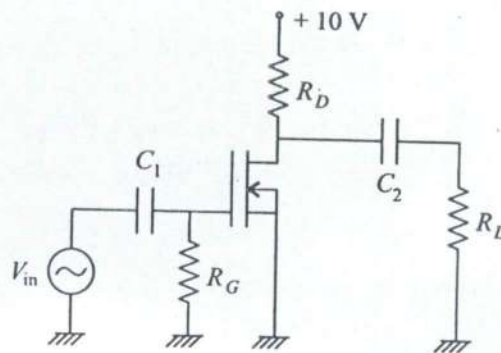

10+10=20

4.(a) Find the eigenvalues and eigenvectors of the matrix $\begin{bmatrix} -2 & 2 & -1 \\ 2 & 1 & -2 \\ -3 & -6 & 0 \end{bmatrix}$ 20

4.(b) A balanced three-phase, 208-Volts generator supplies a total of 1800 Watts at a line current of 10 Amp. When three identical impedances are arranged in Y-connection across the line terminals of the generator calculate the resistive and reactive components of each phase impedance. Sketch also the phase and magnitude relations between phase and line voltages of a Y-connected three-phase system. 20

- 4.(c)
- (i) State the effects of negative feedback in an amplifier.
 - (ii) Draw the circuit diagram of a series voltage negative feedback and derive an expression for its input impedance.
 - (iii) Find the input impedance of a series voltage negative feedback if the gain of the amplifier without feedback is 100,000 and β , the feedback ratio is 0.02.
 - (iv) Draw the electrical equivalent circuit diagram of a crystal oscillator. Derive expression for the resonant frequencies of the oscillator and show the variation of reactance of the crystal with frequency. 4+8+2+6=20

SECTION 'B'

5.(a) What are ferrites ? How they are derived ? Enumerate magnetic, electrical and mechanical properties of ferrites (two each). 12

5.(b) Differentiate between the following :
 (i) Transducers and Inverse Transducers
 (ii) Analog and Digital Transducers
 (iii) Active and Passive Transducers 12

5.(c) (i) Perform the following binary subtraction and give the result in decimal value also :

11001 - 1100 4

(ii) Simplify the Boolean function $F = xy + x'y + xy'$ 4

(iii) Give the output of the following program :

```
int main ( )
{
char str [ ] = "India\0\BIX\0";
printf ("% s\n", str);
return 0;
}
```

4

5.(d) When 100 Volts is applied across a pure resistance, it draws a current of 5 amperes. The uncertainties in measurements of voltage and current are ± 0.2 volts and ± 0.06 ampere respectively. Calculate the power dissipated in resistance and uncertainty in Power in %, when Power P is calculated as $P = VI$. 12

5.(e) Calculate the number of vacancies per cubic meter in iron at 850°C with the following data :

Energy vacancy formation = 1.08 eV/atom

One mole = 6.022×10^{23} atoms

Density at 850°C = 7.65 g/m^3

Atomic weight of iron = 55.85 g/mol

Boltzman's constant = $1.38 \times 10^{-23} \text{ J/atom}\cdot\text{K}$

6.(a) (i) State 3 effects of moisture on insulation and explain any two methods adopted to protect them against moisture along with salient features. 12

(ii) Show that the surface area to volume ratio increases with the reduction in radius of nanoparticle. Plot a graph of surface to volume ratio as a function of radius. 8

6.(b) For the Bridge circuit shown, obtain the expression for mutual inductance M , when the bridge is at balance, in terms of circuit parameters. 20

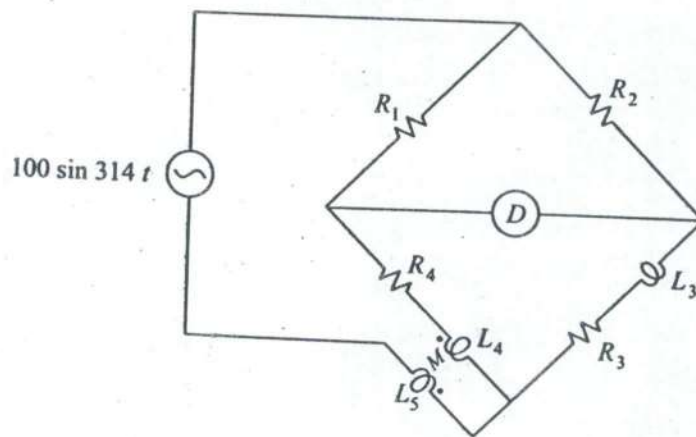

6.(c) (i) Draw the basic organisation of a computer system and indicate the flow of instructions and data. 10

(ii) Explain in brief the functions of each of the units shown in (i). 10

7.(a) (i) For a face centered cubic metal state with reasons the number of atoms assigned per unit cell and coordination number. Also deduce a value for atomic packing factor. 12

(ii) Determine the diameter of the lead wire to pass maximum super current of 0.0021 mA at 5.0 K . The critical temperature and critical magnetic field for lead are respectively 7.18 K and $6.5 \times 10^{-4} \text{ A/m}$. 8

7.(b) The network shown in figure is connected to 3-phase, 400 V, 50 Hz supply with phase sequence *abc*. Calculate the reading of the wattmeter. 20

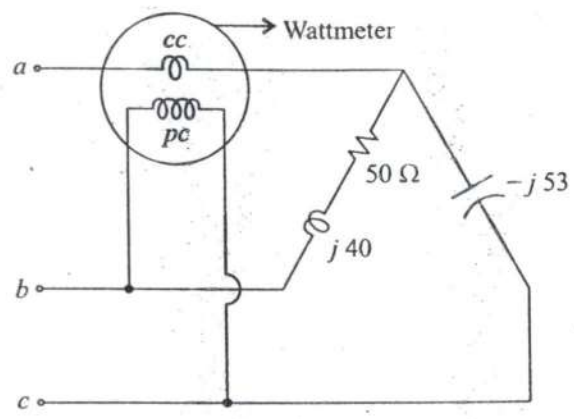

- 7.(c) (i) Bring out the concept of virtual memory and briefly point out its operation. 10
 (ii) What is a page-fault; how is it managed? 10

- 8.(a) (i) Name 5 properties that are exhibited by superconductors. Draw the magnetising curve for Type-I and Type-II superconductors specifying regions of conducting states. 12
 (ii) Explain how some ferrite is suitable for use in a magnetic memory core in computers. Explanation should be based on the hysteresis loop of the ferrite. 8

8.(b) State only the methods to minimise the ratio error of a current transformer.
 A 1000/5 A, 50 Hz current transformer has a bar primary and has total secondary burden of 1 ohm (non-inductive). Calculate the primary current and phase angle error for a rated current of 5 amperes. The magnetising current is 100 A and excitation loss is negligible. 20

- 8.(c) (i) What is a computer network? Distinguish between LAN and WAN. 10
 (ii) Explain in brief what is network topology by illustrating four major topology schemes. 10

