

Serial



TEST BOOKLET

GENERAL STUDIES AND ENGINEERING APTITUDE

Time Allowed : Two Hours

Maximum Marks : 200

INSTRUCTIONS

1. IMMEDIATELY AFTER THE COMMENCEMENT OF THE EXAMINATION, YOU SHOULD CHECK THAT THIS TEST BOOKLET **DOES NOT** HAVE ANY UNPRINTED OR TORN OR MISSING PAGES OR ITEMS, ETC. IF SO, GET IT REPLACED BY A COMPLETE TEST BOOKLET.
2. Please note that it is the candidate's responsibility to encode and fill in the Roll Number and Test Booklet Series Code A, B, C or D carefully and without any omission or discrepancy at the appropriate places in the OMR Answer Sheet. Any omission/discrepancy will render the Answer Sheet liable for rejection.
3. You have to enter your Roll Number on the _____
Test Booklet in the Box provided alongside.
DO NOT write *anything else* on the Test Booklet. _____
4. This Test Booklet contains 100 items (questions). Each item comprises four responses (answers). You will select the response which you want to mark on the Answer Sheet. In case, you feel that there is more than one correct response, mark the response which you consider the best. In any case, choose **ONLY ONE** response for each item.
5. You have to mark your responses **ONLY** on the separate Answer Sheet provided. See directions in the Answer Sheet.
6. All items carry equal marks.
7. Before you proceed to mark in the Answer Sheet the response to various items in the Test Booklet, you have to fill in some particulars in the Answer Sheet as per instructions sent to you with your Admission Certificate.
8. After you have completed filling in all your responses on the Answer Sheet and the examination has concluded, you should hand over to the Invigilator **only the Answer Sheet**. You are permitted to take away with you the Test Booklet.
9. Sheets for rough work are appended in the Test Booklet at the end.
10. **Penalty for wrong answers :**
THERE WILL BE PENALTY FOR WRONG ANSWERS MARKED BY A CANDIDATE.
 - (i) There are four alternatives for the answer to every question. For each question for which a wrong answer has been given by the candidate, **one-third (0.33)** of the marks assigned to that question will be deducted as penalty.
 - (ii) If a candidate gives more than one answer, it will be treated as a **wrong answer** even if one of the given answers happens to be correct and there will be same penalty as above to that question.
 - (iii) If a question is left blank, i.e., no answer is given by the candidate, there will be **no penalty** for that question.

DO NOT OPEN THIS TEST BOOKLET UNTIL YOU ARE TOLD TO DO SO

1. Government of India had introduced the Consumer Protection Bill, 2015, in the Lok Sabha. The Bill gives the right to consumers to

1. Seek redressal against unfair or restrictive trade practices.
2. File a complaint for overcharging or deceptive charging.

Which of the above is/are included in the Bill ?

- (a) 1 only
- (b) 2 only
- (c) Both 1 and 2
- (d) Neither 1 nor 2

2. Technology Promotion, Development and Utilization Programme implemented by Department of Scientific and Industrial Research has which of the following components ?

1. Industrial R&D Promotion Programme
2. Flagship Programme
3. Information Technology and e-Governance

- (a) 1 and 2 only
- (b) 1 and 3 only
- (c) 2 and 3 only
- (d) 1, 2 and 3

3. The Olympic Flame symbolizes

- (a) Unity among various nations of the world
- (b) Speed, perfection and strength
- (c) The development of sportsmanship
- (d) Continuity between ancient and modern games

4. Consider the following statements :

1. IPDS strengthens the distribution network in urban areas while DDUGJY does the same in rural areas.
2. DELP focuses to substitute LED bulbs for incandescent bulbs.

Which of the above statements is/are correct ?

- (a) 1 only
- (b) 2 only
- (c) Both 1 and 2
- (d) Neither 1 nor 2

5. Consider the following statements :

Non-performing assets (NPAs) decline in value when

1. Demand revives in the economy.
2. Capacity utilization increases.
3. Capacity utilization, though substantive, is yet sub-optimal.
4. Capacity utilization decreases consequent upon merger of units.

Which of the above statements are correct ?

- (a) 1, 3 and 4 only
- (b) 1, 2 and 4 only
- (c) 1, 2 and 3 only
- (d) 1, 2, 3 and 4

6. The meaning of 'Carbon Footprint' is described by the amount of

- (a) Carbon dioxide released into the atmosphere as a result of the activities of a particular individual, organization or community
- (b) Greenhouse gases emitted by industries contributing to global warming
- (c) Carbon emissions released by the burning of jet fuel
- (d) Increase in the carbon content of the atmosphere due to the felling of trees

7. What is Crowdfunding ?
- Money collected for public welfare projects by levying an entry fee to exhibitions, shows, etc.
 - Money collected by charitable organizations by placing a donation box at prominent locations
 - Money raised by innovators and inventors by launching their products and services through the Internet
 - Money raised by individuals by passing the hat around to onlookers at a street performance

8. The sum of squares of successive integers 8 to 16, both inclusive, will be
- 1126
 - 1174
 - 1292
 - 1356

9. Consider a trapezoidal lamina ABCD, with AB parallel to DC, 6 cm apart; AB is 8 cm; CD is 12 cm; CD extends outwards by 1 cm from the foot of the perpendicular from B on DC. The centre of gravity of the lamina will be
- Along AC at a height of 3 cm from DC
 - Along BD at a height of 3 cm from DC
 - Along the line joining the mid-point of AB to the mid-point of DC; at a height of 2.8 cm from DC
 - At the intersection point of AC and DB

10. A cantilever beam ABC is shown to a highly exaggerated vertical scale. Horizontally, AB is 2 m long and BC is 0.6 m long. Loads act only in the region AB, and there are no loads in the region BC. Under this load system, the deflection at B is 0.24 cm and the slope of the beam at B is θ , where $\sin \theta = 0.038$. What is the deflection at D, which is midway between B and C ?

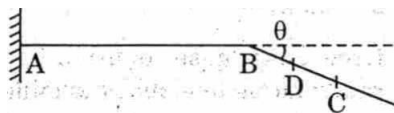

- 0.2406 cm
- 0.2514 cm
- 0.2530 cm
- 0.2452 cm

11. Given that 0.8 is one root of the equation, $x^3 - 0.6x^2 - 1.84x + 1.344 = 0$. The other roots of this equation will be

- 1.1 and -1.4
- 1.2 and 1.4
- 1.2 and -1.4
- 1.1 and 1.4

12. The equation, $x^3 - 8x^2 + 37x - 50 = 0$ is factored and it has $(3 + 4i)$ as one of its roots. What is the real root of this equation ?

- 2
- 4
- 6.5
- 13

13. Circle A is 4 cm in diameter; circle B is 5 cm in diameter. Circle C has its circumference equal to the sum of the circumferences of both A and B together. What will be the ratio of the area of circle C, with respect to the area of circle A and circle B respectively ?

- 5.0625 and 1.84
- 3.875 and 1.84
- 5.0625 and 3.24
- 3.875 and 3.24

14. The 12 digits on the face of a clock are to be represented employing contributions of only the number 9 as either 9 or $\sqrt{9}$. The other prescribed conditions are (i) the least number of uses alone are permitted; and (ii) when alternates are possible, use of 9 will be preferred over use of $\sqrt{9}$, which should be used minimally. How many times would $\sqrt{9}$ have to be used ?

- 6
- 5
- 4
- 3

15. In a particular test, the marks scored by 4 candidates — A, B, C and D are as follows :

- Marks obtained by A and B add to 100;
- Marks obtained by C and D add up to those scored by A;
- B scores 4 times of D;
- D scores 10 marks less than C.

The marks obtained by C will be

- C-D=10*
C+D=100
5C-4D=100
5C-4(C-10)=100
5C-4C+40=100
C+40=100
C=60
- (a) 30
(b) 15
(c) 20
 (d) 25

16. In a project there are 9 activities : A, B, C, D which are sequential; E, F, G which are sequential; H, K which are sequential. Also E, F, G run parallel to B, C, D; and H, K run parallel to A, B, C, D. Besides these activity dependencies, it is also needful that B be completed before taking up G; A and H be completed before taking up D and K. How many dummies are to be drawn on the activity network ?

- (a) 5
(b) 4
(c) 3
(d) 2

17. What is the form of the function $f(x)$ for the following data ?

x	0	1	2	3
f(x)	3	6	11	18

- (a) $x^2 + 2x + 3$
(b) $x^2 - 2x + 3$
(c) $x^2 + 2x - 3$
(d) $x^2 - 2x - 3$

18. Let the Eigenvector of the matrix $\begin{bmatrix} 1 & 2 \\ 0 & 2 \end{bmatrix}$ be

written in the form $\begin{bmatrix} 1 \\ a \end{bmatrix}$ and $\begin{bmatrix} 1 \\ b \end{bmatrix}$. What is the value of $(a + b)$?

- (a) 0
(b) $\frac{1}{2}$
(c) 1
(d) 2

19. What is the cube root of 1468 to 3 decimal places ?

- (a) 11.340
(b) 11.353
(c) 11.365
(d) 11.382

20. Let $f(x) = \begin{cases} -\pi, & \text{if } -\pi < x \leq 0 \\ \pi, & \text{if } 0 < x \leq \pi \end{cases}$

be a periodic function of period 2π . The coefficient of $\sin 5x$ in the Fourier series expansion of $f(x)$ in the interval $[-\pi, \pi]$ is

- (a) $\frac{4}{5}$
(b) $\frac{5}{4}$
(c) $\frac{4}{3}$
(d) $\frac{3}{4}$

21. What is the value of $(1525)^{0.2}$ to 2 decimal places?

- (a) 4.33
- (b) 4.36
- (c) 4.38
- (d) 4.30

22. In the Laurent expansion of

$$f(z) = \frac{1}{(z-1)(z-2)} \text{ valid in the region}$$

$1 < |z| < 2$, the coefficient of $\frac{1}{z^2}$ is

- (a) 0
- (b) $\frac{1}{2}$
- (c) 1
- (d) -1

23. If $u = \log \left(\frac{x^2 + y^2}{x + y} \right)$, what is the value of

$$x \frac{\partial u}{\partial x} + y \frac{\partial u}{\partial y} ?$$

- (a) 0
- (b) 1
- (c) u
- (d) eu

24. What is the residue of the function $\frac{1 - e^{2z}}{z^4}$ at its pole?

- (a) $\frac{4}{3}$
- (b) $-\frac{4}{3}$
- (c) $-\frac{2}{3}$
- (d) $\frac{2}{3}$

25. What is the maximum value of z, if $z = 10x + 6y$ subject to the constraints

$$3x + y \leq 12, \quad 2x + 5y \leq 34, \quad x \geq 0, \quad y \geq 0 ?$$

- (a) 56
- (b) 52
- (c) 50
- (d) 40

26. Which of the following concepts are relatable to income of members of the public while considering public welfare?

1. Sensitivity of demand
2. Elasticity of demand
3. Sensitivity of expenditure
4. Elasticity of expenditure

- (a) 1 and 2 only
- (b) 2 and 3 only
- (c) 3 and 4 only
- (d) 1 and 4 only

27. Consider the following provisions regarding safety on highways, where major improvement works may also be in progress :

1. Highly visible barricades to avoid falling of vehicles in deep interspaces ahead (including drainages)
2. Wire-net provisions to ward off road slippages
3. Signages for wild-animals crossing (like deer, elephant, etc.)
4. Signages on minor gradients

Which of the above are relevant ?

- (a) 1, 2, 3 and 4
- (b) 1, 2 and 4 only
- (c) 1, 3 and 4 only
- (d) 1, 2 and 3 only

28. A vehicle moving at a speed of 88 km/hr weighs 62293.5 N and its rolling resistance coefficient is 0.018. The rolling resistance of the vehicle is

- (a) 1121.3 N
- (b) 1000.4 N
- (c) 975.7 N
- (d) 845.6 N

29. For a vehicle travelling at 24 km/hr having a wheel radius of 0.305 m with overall gear ratio $G = 19.915$, and when torque transmitted is 203.6 N.m, the engine speed and power are, nearly

- (a) 4155 rpm and 88.6 kW
- (b) 4500 rpm and 88.6 kW
- (c) 4155 rpm and 95.4 kW
- (d) 4500 rpm and 95.4 kW

30. A rod of length L , cross-section area A_1 and modulus of elasticity E_1 , has been placed inside a tube of length L , of cross-section area A_2 and modulus of elasticity E_2 , and the two are firmly held by end plates. The portion of the load P applied on the end plates shared by rod and tube, respectively, are

(a) $\frac{P A_1 E_1}{A_1 E_1 + A_2 E_2}$ and $\frac{P A_2 E_2}{A_1 E_1 + A_2 E_2}$

(b) $\frac{P A_2 E_2}{A_1 E_1 + A_2 E_2}$ and $\frac{P A_1 E_1}{A_1 E_1 + A_2 E_2}$

(c) $\frac{P A_1 E_1}{A_1 E_1 + A_2 E_1}$ and $\frac{P A_2 E_2}{A_1 E_2 + A_2 E_2}$

(d) $\frac{P A_1 E_1}{A_1 + A_2}$ and $\frac{P A_2 E_2}{A_1 + A_2}$

31. A weight of 240 N is dropped on to a close-coiled helical spring made up of 18 mm spring steel wire. The spring consists of 22 coils wound to a diameter of 180 mm. If the instantaneous compression is 120 mm; what is the height of drop of the weight, given $G = 88 \times 10^3 \text{ N/mm}^2$?

- (a) 450 mm
- (b) 300 mm
- (c) 250 mm
- (d) 150 mm

32. Consider the following statements regarding Ergonomic Design :

1. Reducing the stress on the spinal cord and providing for lesser fatigue-causing sitting arrangements.
2. Arrangements of keys on the computer keyboard towards optimizing finger stress level.
3. Catering to increasing demand to produce more pleasing objects.

Which of the above statements are correct ?

- (a) 1 and 2 only
- (b) 2 and 3 only
- (c) 1 and 3 only
- (d) 1, 2 and 3

33. Which type of output device creates coloured images which look and feel like photographs ?

- (a) Electrostatic plotter
- (b) Laser printer
- (c) Dye sublimation printer
- (d) Inkjet plotter

34. Consider the following statements with reference to Six-Sigma :

1. It is a set of techniques and tools for process improvement.
2. It postulates that any process must not produce more than 3.4 defects per one million opportunities.
3. It is an initiative of Motorola.

Which of the above statements are correct ?

- (a) 1 and 2 only
- (b) 1 and 3 only
- (c) 2 and 3 only
- (d) 1, 2 and 3

35. Consider the following statements regarding a Grillage Foundation :

1. It is provided for heavily loaded isolated columns.
2. It is treated as a spread foundation.
3. It consists of two sets of perpendicularly placed steel columns.

Which of the above statements are correct ?

- (a) 1 and 2 only
- (b) 1 and 3 only
- (c) 2 and 3 only
- (d) 1, 2 and 3

36. Consider the following statements regarding Insolation :

1. It is the solar radiation that reaches the Earth's surface.
2. It is measured by the amount of solar energy received per square centimeter per minute.
3. It is the amount of solar energy absorbed by the stratosphere.

Which of the above statements are correct ?

- (a) 1, 2 and 3
- (b) 1 and 2 only
- (c) 1 and 3 only
- (d) 2 and 3 only

37. Consider the following statements regarding Quality Circle :

1. It is a small group of people working in different areas of an organization with multiple expertises.
2. It consists of people who volunteer themselves.
3. It is a human resource development technique.
4. It is a problem-solving forum.

Which of the above statements are correct ?

- (a) 2, 3 and 4 only
- (b) 1, 2 and 3 only
- (c) 1, 3 and 4 only
- (d) 1, 2 and 4 only

38. Consider the following statements :

1. In work breakdown structure, top-down approach is adopted.
2. Duration along critical path is the shortest duration permissible.
3. PERT is probabilistic in its approach.

Which of the above statements are correct ?

- (a) 1 and 2 only
- (b) 1 and 3 only
- (c) 2 and 3 only
- (d) 1, 2 and 3

39. Let the sum of the squares of successive integers 0, 1, 2, ..., n - 1, n be denoted by S. Let the sum of the cubes of the same integers be denoted by C. It is desirable that $\frac{C}{S}$, as n increases in steps of 'unity' from 'zero', is given by the series :

$$\frac{0}{1}, \frac{3}{3}, \frac{9}{5}, \frac{18}{7}, \frac{30}{9}, \dots \text{ (for } n = 0, 1, 2, 3, 4, \dots \text{)}$$

What will this ratio be for n = 8 ?

- (a) $\frac{108}{17}$
- (b) $\frac{103}{17}$
- (c) $\frac{103}{15}$
- (d) $\frac{100}{15}$

40. The plan view at just below window-sill level, but not showing door openings - is shown - of an outpost building of, say, the Forest Department. Section AA extending just a little above ground level GL and fully below ground level is shown. The wall and first footing are of random-rubble masonry in cement mortar; and the lowest part of the foundation is of mass rubble in cement mortar. The total volume of the 40 cm deep footing for the whole building is, nearly

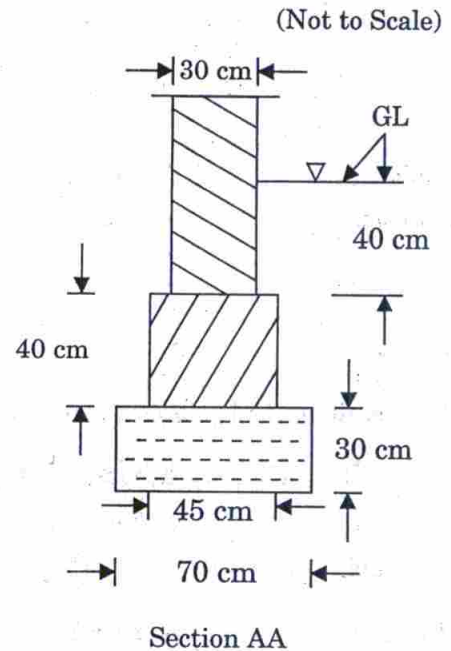
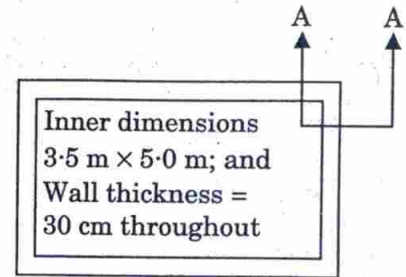

- (a) 3.8 m^3
- (b) 3.3 m^3
- (c) 2.8 m^3
- (d) 2.3 m^3

41. Consider the following statements with regard to atmospheric humidity :

1. Absolute humidity is the amount of water vapour per unit volume.
2. Hygrometer is used to measure relative humidity.
3. Dew point is the temperature at which the relative humidity is 75%.

Which of the above statements are correct ?

- (a) 1 and 2 only
- (b) 1 and 3 only
- (c) 2 and 3 only
- (d) 1, 2 and 3

42. Sanitary/municipal fills and waste heaps are unavoidably hazardous due to

1. Leachates
2. Emanating gases
3. Rodents and wandering animals
4. Automobile workshops that seem to have an affinity for such neighbourhoods

Which of the above are correct ?

- (a) 1 and 4 only
- (b) 1 and 2 only
- (c) 2 and 3 only
- (d) 3 and 4 only

43. Consider the following statements regarding depletion of the ozone layer :

1. Excessive release of chlorine and bromine in the environment from man-made compounds, such as chlorofluorocarbons.
2. Occurrence of certain natural phenomena such as sunspots, and stratospheric winds.
3. Degradation of materials by ultra-violet radiation.
4. Major volcanic eruptions.

Which of the above can be categorized as causing ozone depletion ?

- (a) 1, 2 and 3 only
- (b) 1, 3 and 4 only
- (c) 1, 2 and 4 only
- (d) 2, 3 and 4 only

44. Which one of the following is the major characteristic of deciduous trees ?

- (a) They do not lose their leaves.
- (b) They shed their leaves annually.
- (c) They synthesize their own food.
- (d) They depend on other factors for their food.

45. A wall, rectangular in shape, has a perimeter of 72 m. If the length of its diagonal is 18 m, what is the area of the wall ?

- (a) 224 m^2
- (b) 486 m^2
- (c) 572 m^2
- (d) 606 m^2

46. To isolate an enclosed area for conservation, an open traverse is run keeping close to (but outside of) the exterior boundary of the area through ground points A → B → C → D → E → F → G → towards H (to be eventually located). AB is 80° to the East of the North line at A. Deflection/Interior angles at B, C, D, E, F are indicated. What would be the magnitude of the deflection angle at G (as marked) so that GH may run parallel to BA? (Lengths are immaterial in this case.)

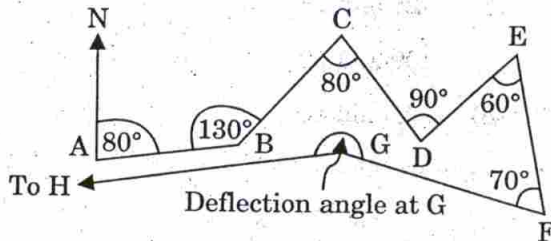

- (a) 190°
 (b) 210°
 (c) 200°
 (d) 230°

47. Consider the following characteristics with respect to Alpha particles :

1. They have large specific ionization values.
2. They dissipate their energy rather slowly.
3. They can penetrate the outer layer of human skin.
4. Their emitters are heavy elements.

Which of the above statements are correct ?

- (a) 1 and 4 only
 (b) 1 and 3 only
 (c) 2 and 4 only
 (d) 2 and 3 only

48. Increased biological oxygen demand is an indication of

1. Low microbial contamination.
2. Absence of microbial pollution.
3. High level of microbial contamination.

Which of the above statements is/are correct ?

- (a) 1 only
 (b) 2 only
 (c) 3 only
 (d) 1, 2 and 3

49. An association of two organisms of different species for mutual benefit, and where the individuals may not be able to survive separately, is called

- (a) Commensalism
 (b) Parasitic
 (c) Non-symbiotic
 (d) Symbiotic

50. A simple project comprises of two start-to-end parallel paths, each with three activities in series, with no interpath dependencies. The a, m, b data (in days) for each activity are shown in the diagram. Assuming that three activities in series are enough for further computations, what will be the total project duration and its standard deviation ?

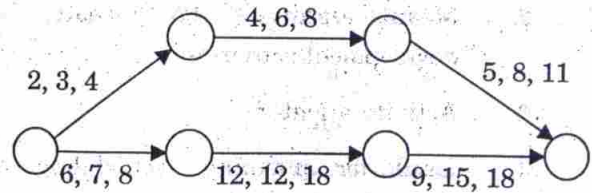

- (a) $35\frac{1}{2}$ days and $\frac{14}{3}$ days
 (b) $34\frac{1}{2}$ days and $\frac{5}{2}$ days
 (c) $35\frac{1}{2}$ days and $\frac{13}{6}$ days
 (d) $34\frac{1}{2}$ days and $\frac{11}{6}$ days

51. Crashing is

- (a) Abandoning the project
- (b) Completing the project with all possible haste
- (c) Reduction of duration for a few of the activities
- (d) Reducing the cost of the project with all needful modifications

52. ABC analysis in materials management is a method of classifying the inventories based on the

- (a) Economic order quantity
- (b) Value of annual usage of the items
- (c) Volume of material consumption
- (d) Quantity of materials used

53. CPM method of network analysis is

1. Ideally suited for linearly extending works.
2. Meant essentially for research and development activities.
3. Activity-oriented.
4. Used for planning, scheduling and controlling purposes.

Which of the above statements are correct ?

- (a) 1 and 2 only
- (b) 2 and 3 only
- (c) 3 and 4 only
- (d) 1 and 4 only

54. The objective function $z = 3x_1 + 5x_2$ is to be maximized subject to constraints

$$x_1 + 2x_2 \leq 200$$

$$x_1 + x_2 \leq 150$$

$$x_1, x_2 \geq 0$$

The values of x_1 and x_2 in this context are, respectively

- (a) 100 and 75
- (b) 125 and 75
- (c) 100 and 50
- (d) 125 and 50

55. Consider the length of a room is 15 m and width is 10 m. If the sum of the areas of the floor and ceiling is equal to the sum of the areas of the four walls, then the volume of the room is

- (a) 900 m^3
- (b) 1000 m^3
- (c) 1200 m^3
- (d) 1500 m^3

56. If the EOQ is 360 units, order cost is ₹ 5 per order and carrying cost is ₹ 0.20 per unit, what is the usage ?

- (a) 2654 units
- (b) 2592 units
- (c) 1872 units
- (d) 1574 units

57. If L_j = the latest occurrence time for event j ,
 E_i = the earliest occurrence time for event i ,
 T_{ij} = the duration of activity \overrightarrow{ij} ,
 what is the total float for activity \overrightarrow{ij} ?
- (a) $E_i - L_j - T_{ij}$
 (b) $L_j - E_i - T_{ij}$
 (c) $T_{ij} - E_i - L_j$
 (d) $T_{ij} - L_j + E_i$
58. The process of removing irregular portions of stones and facilitating their easy transportation is known as
- (a) Quarrying
 (b) Reticulating
 (c) Dressing
 (d) Pointing
59. On which of the following factors does hysteresis loss depend ?
1. Magnetic field intensity
 2. Frequency of the field
 3. Volume of material
 4. Néel temperature
- (a) 1, 2 and 4 only
 (b) 1, 3 and 4 only
 (c) 2, 3 and 4 only
 (d) 1, 2 and 3 only
60. What is the volume of an FCC unit cell in terms of its atomic radius R ?
- (a) $\sqrt{3} R^3$
 (b) $16 R^3 \sqrt{2}$
 (c) $16 R^3 \sqrt{3}$
 (d) $\sqrt{2} R^3$
61. How much sulphur is required per 100 kg of final rubber product to completely crosslink butadiene rubber ?
- (a) 17 kg
 (b) 27 kg
 (c) 37 kg
 (d) 47 kg
62. Which one of the following is termed as sacrificial protection of metal ?
- (a) Galvanization
 (b) Tinning
 (c) Organic coating
 (d) Inorganic coating
63. The material used in the production of bearings is
- (a) Cast iron
 (b) Babbitt metal
 (c) Pig iron
 (d) Steel
64. Malleable cast iron is produced
1. By quick cooling of cast iron.
 2. By adding magnesium to molten cast iron.
 3. From white cast iron by annealing.
- Which of the above statements is/are correct ?
- (a) 1 only
 (b) 2 only
 (c) 3 only
 (d) 1, 2 and 3
65. The critical temperature above which ferromagnetic materials lose their magnetic property is called
- (a) Kelvin point
 (b) Curie point
 (c) Recrystallization point
 (d) Celsius point

66. The Hall Effect may be used to
1. Determine whether the semiconductor is p-type or n-type.
 2. Determine the carrier concentration.
 3. Calculate the mobility.
- Which of the above statements are correct ?
- (a) 1 and 2 only
 - (b) 1 and 3 only
 - (c) 2 and 3 only
 - (d) 1, 2 and 3
67. Which of the following sets of free software tools are suitable for ICT-based education as well as an open source ?
- (a) Scilab, Osdag, PHP and Latex
 - (b) Java, LibreOffice, Audacity and Matlab
 - (c) Scilab, Arduino, LibreOffice and Latex
 - (d) Scilab, Octave, Netduino and Latex
68. Which of the following are the benefits of e-governance system ?
1. Simplicity, efficiency and accountability
 2. Quality service to citizens
 3. Better access to information
 4. Expanded reach of governance
- (a) 1, 2 and 3 only
 - (b) 1, 2 and 4 only
 - (c) 3 and 4 only
 - (d) 1, 2, 3 and 4
69. What does CDMA stand for ?
- (a) Code Division Mobile Access
 - (b) Code Division Multiple Access
 - (c) Code Division Multiple Applications
 - (d) Code Division Mobile Applications

70. A small production unit now works 6 days per week with $3\frac{1}{2}$ hours of first shift every one of the 6 days and 3 hours of second shift for each of the first 5 days. Wage negotiations led to an agreement to work on 5 days a week with both shifts together clocking $7\frac{1}{2}$ hours per day with an 8% increase in weekly wages. How much change in the hourly production would mean parity in the agreement for both management and employees ?
- (a) 3.68%
 - (b) 2.15%
 - (c) 1.82%
 - (d) 1.33%
71. Consider the following statements :
1. National Agricultural Portal, eNAM, is designed to create a unified national market for agricultural commodities.
 2. Farmers can showcase their produce online from the nearest market and the buyer can quote his price from anywhere.
- Which of the above statements is/are correct ?
- (a) 1 only
 - (b) 2 only
 - (c) Both 1 and 2
 - (d) Neither 1 nor 2
72. Consider the following statements regarding the code of ethics for Engineers :
1. The safety, health and welfare of the public are of paramount importance.
 2. Perform services only in the area of their competence.
 3. Issue public statements strictly in an objective and truthful manner.
 4. Avoid deceptive acts.
- Which of the above statements are correct ?
- (a) 1, 2 and 3 only
 - (b) 1, 2 and 4 only
 - (c) 3 and 4 only
 - (d) 1, 2, 3 and 4

73. In a radar system, the term 'Rat-Race' is used in connection with
- Modulator
 - Pulse characteristics
 - Receiver Bandwidth
 - Duplexer
74. Consider the following statements :
1. Material science deals with the strength and stiffness behaviour of components (buildings/machines/vehicle facilities) based on their response to imposed stresses (forces, moments, torque, etc.).
 2. Material properties are dependent on their micro-structure and response to force fields and surface interaction.
- Which of the above statements is/are correct ?
- 1 only
 - 2 only
 - Both 1 and 2
 - Neither 1 nor 2
75. PQLI is based on
- Infant mortality, life expectancy and adult literacy rate
 - Crime rate, clean environment and quality of housing
 - Air pollution, water pollution and sanitation conditions
 - Health, education and environment
76. HDI is a better index of development because
- GDP growth may not consider personal growth situations
 - It takes into consideration reduction of poverty
 - It covers income, health and education aspects of development
 - It covers promotion of growth
77. IPR protects the use of information and ideas that are of
- Ethical value
 - Moral value
 - Social value
 - Commercial value
78. A Whistleblower is someone who
- Whistles classical music
 - Informs on any illegal, unethical or corrupt activity going on in the organisation
 - Is adept in whistling
 - Boasts about himself/herself
79. What is meant by 'Conflict of Interest' ?
- Being interested in many subjects
 - Hobbies interfering in education
 - Least interest in the job taken up or assigned
 - A conflict between the private interests and the official responsibilities of a person in a position of trust
80. What is 'Nepotism' ?
- Undermining the morale of workers
 - Harassment of women workers
 - Being autocratic in decision-making
 - Hiring friends or relatives and showing favouritism in work

Directions : Each of the next **twenty (20)** items consists of two statements, one labelled as 'Statement (I)' and the other as 'Statement (II)'. Examine these two statements carefully and select the answers to these items using the codes given below :

Codes :

- (a) Both Statement (I) and Statement (II) are individually true and Statement (II) is the correct explanation of Statement (I)
- (b) Both Statement (I) and Statement (II) are individually true, but Statement (II) is **not** the correct explanation of Statement (I)
- (c) Statement (I) is true, but Statement (II) is false
- (d) Statement (I) is false, but Statement (II) is true

81. *Statement (I) :*

Atoms can neither be created nor destroyed.

Statement (II) :

Under similar conditions of temperature and pressure, equal volumes of gases do not contain an equal number of atoms.

82. *Statement (I) :*

Lifts and external staircases are provided with access from the lobby area of each floor in multistorey blocks. The external staircase must be accessible through self-closing, 180°-swing unlocked doors (with provision for locking at appropriate conditions).

Statement (II) :

Such staircases should not be inadvertently subjected to spreading of smoke, but must yet provide unhindered exit from the lobby of each floor.

83. *Statement (I) :*

Volcanic eruption is often accompanied by earthquakes.

Statement (II) :

Volcanoes erupt dust particles in the atmosphere.

84. *Statement (I) :*

Quality is essential for survival and growth of an organisation in the present era of tough competition.

Statement (II) :

The concept of quality is confined only to construction and manufacturing organisations.

85. *Statement (I) :*

The concept of Just-In-Time is operationalized when the exact number of units required are bought at each successive stage of production, at the appropriate time.

Statement (II) :

Just-In-Time concept has been expanded to mean a manufacturing philosophy of eliminating waste.

86. *Statement (I) :*

Total Productive Maintenance (TPM) is productive maintenance involving total participation as a group activity.

Statement (II) :

Under the aegis of TPM, individual operators generally take care of minor maintenance aspects.

87. *Statement (I) :*

Green energy refers to one which does not harm the ecosystem of planet Earth.

Statement (II) :

All renewable energy is green energy.

88. *Statement (I) :*

To practise terraced cultivation in hill slopes, it can be admissible to have the vertical face of the terraced boundary run perpendicular to the ground trace of the fault line, if any, in the underlying land.

Statement (II) :

Fault lines are susceptible to slips and should be guarded against in land use.

89. *Statement (I) :*
Normally carbon dioxide is not considered an air pollutant.
Statement (II) :
Carbon dioxide is a constituent of atmospheric air.
90. *Statement (I) :*
The size of a hydrogen balloon increases as it rises in the air.
Statement (II) :
The material of the balloon can be easily stretched.
91. *Statement (I) :*
Preparation of bar charts is merely a scheduling operation while the preparation and analysis of a network is a planning function.
Statement (II) :
A bar chart, prima facie, does not show the interrelationships between activities.
92. *Statement (I) :*
Project management is essentially the process to plan its implementation and to pre-determine the period-wise need of resources including funds and personnel, given the choice of total duration and quality standards.
Statement (II) :
Of the four dimensions (not denying that there can be some more) of a project, viz., scope, cost, time and quality, only any two can be pre-assigned; others have to abide by these two prescriptions.
93. *Statement (I) :*
High strength, super-duralumin alloys are adopted in the manufacture of aero engines.
Statement (II) :
Precipitation heat treatment is adopted for duralumin products.
94. *Statement (I) :*
Metal carbides and carbon are used as refractories as they resist oxidation.
Statement (II) :
Metal carbides and carbon are not particularly suitable for high temperature applications.
95. *Statement (I) :*
Long chain polymers are weaker than most ceramics and metals.
Statement (II) :
The molecular chains in long chain polymers are bonded to each other with Van der Waals bonds.
96. *Statement (I) :*
Mechanically, pearlite has properties intermediate between the soft ductile ferrite and the hard brittle cementite.
Statement (II) :
Alpha iron can be made magnetic above 768°C.
97. *Statement (I) :*
Information and communication technologies can play a key role in the development and economic growth of rural India.
Statement (II) :
Successful ICT application in e-governance giving respective one-stop solutions for rural communities is an absolute need of the hour.
98. *Statement (I) :*
Increasingly, employers have generally tended to expect engineers to possess both hard skills and soft skills.
Statement (II) :
Soft skills mean the knowledge of software.
99. *Statement (I) :*
What is legal may not always be ethical.
Statement (II) :
Ethical standards and the law, share the same theme, i.e., what is permissible and impermissible.
100. *Statement (I) :*
A greenhouse gas is any gas in the atmosphere which absorbs and re-emits heat and thereby keeps the planet's atmosphere warmer than it otherwise would be.
Statement (II) :
In the Earth's atmosphere, water vapour is one of the main greenhouse gases.